

Panel cut-out

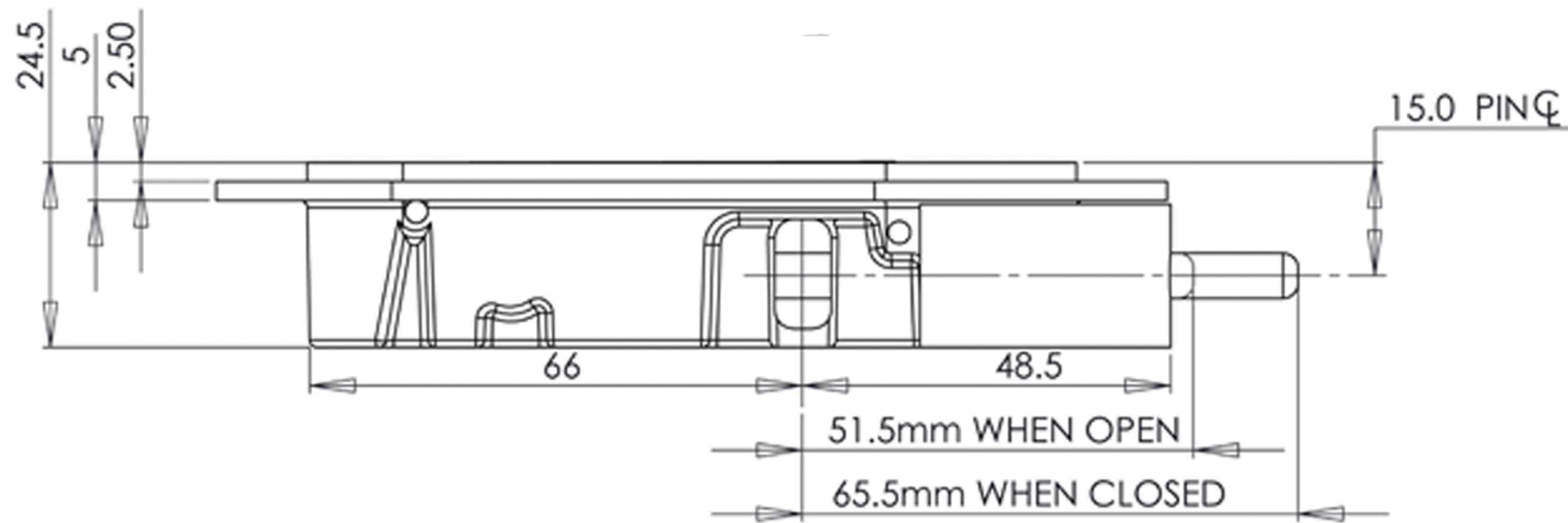

NOT TO SCALE

A		FIRST ISSUE		
ISSUE	ECN NO.-	REVISION	BY	DATE
DRAWN		DATE		MATERIAL:
APPVD		DATE		TREATMENT:
				FINISH:
TITLE:		AEROCATCH 2		PROJECTION:
225 SERIES BELOW PANEL DIMENSIONS AND PANEL CUT-OUT		THIRD ANGLE		<small>THE DOCUMENT AND COPYRIGHT HEREIN ARE THE PROPERTY OF CLARENDON SPECIALTY FASTENERS LTD AND MAY ONLY BE USED OR COPIED IF AUTHORISED IN WRITING BY CLARENDON SPECIALTY FASTENERS LTD</small>
		225 SERIES		
SCALE: 2:1		SHEET 1 OF 1		A3

Clarendon
Specialty Fasteners
Unit D, Seymour Wharf, Steamer Quay
Road Totnes, Devon, TQ9 5AL

TOLERANCES:

UNLESS OTHERWISE SPECIFIED:
DIMENSIONS ARE IN MILLIMETRES

	LINEAR:	
	METRIC	INCH
X	±0.50	X ±.020
X.X	±0.25	.XX ±.010
X.XX	±0.12	.XXX ±.005

ALL TOOL TIP RADII R0.4 UNLESS OTHERWISE STATED

ANGULAR: ± 1°

TITLE: AEROCATCH 2

225 SERIES BELOW PANEL DIMENSIONS AND PANEL CUT-OUT

DRAWN	DATE	MATERIAL:
APPVD	DATE	TREATMENT:
		FINISH:

DWG NO.	225 SERIES
SCALE: 2:1	SHEET 1 OF 1