

CATALOGO • 2018 • CATALOGUE

Sabelt[®]

2018

Sabelt[®]

Sabelt S.p.A.
Via Guido Rossa, 8/10/12
10024 Moncalieri (TO) Italia
Tel. +39 011 6477911
Fax +39 011 6477999
info@sabelt.com

www.sabelt.com

 @sabeltofficial

 sabeltofficial

 Sabelt S.p.A.

Sabelt

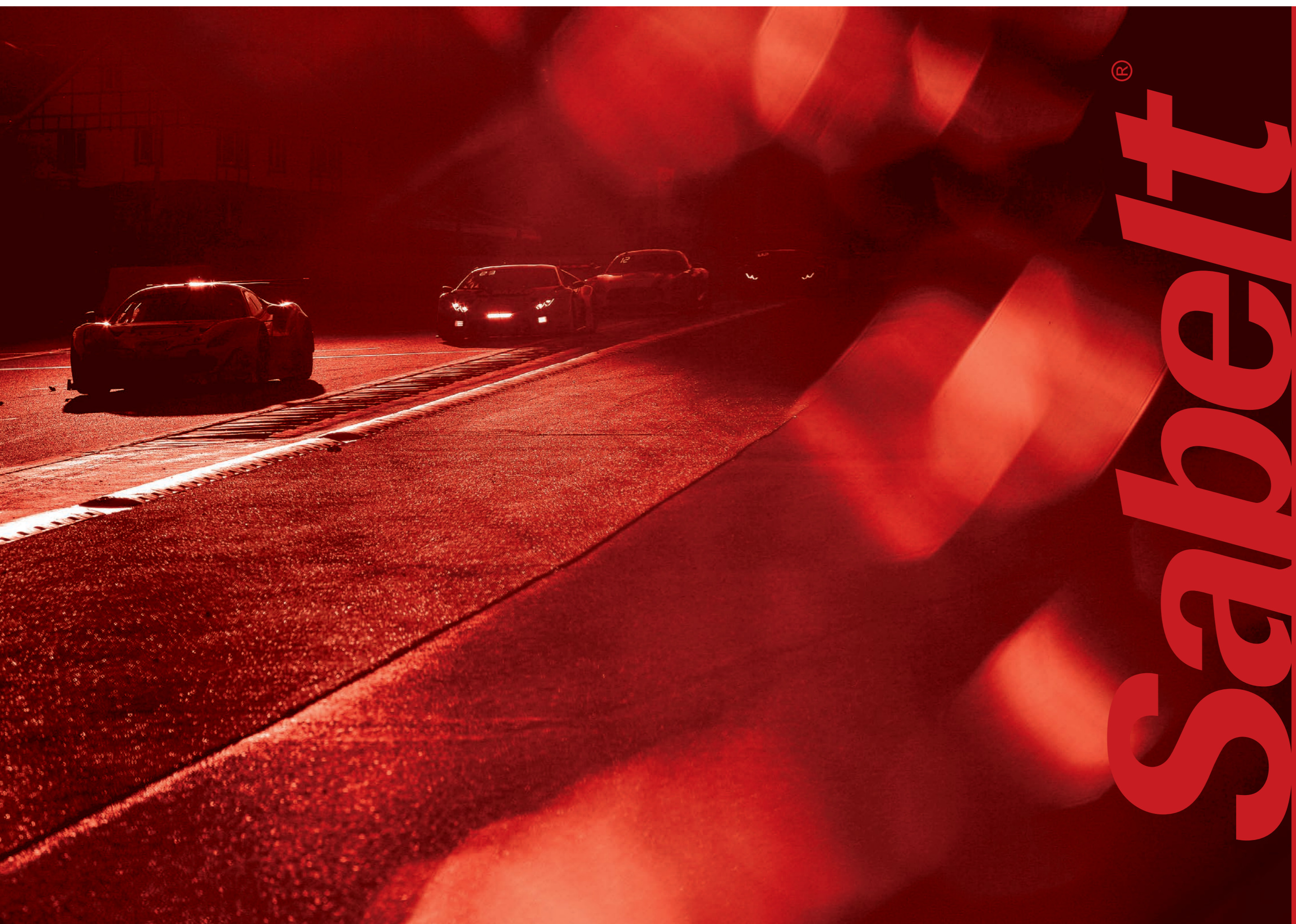

Sabelt®

HARNESSES

2

OEM / SPECIAL APP

6

RACING

12

SABELT VALUES

40

HERITAGE

La storia di ognuno testimonia ciò che siamo stati capaci di essere ed identifica chiaramente quello che potremo diventare.

Siamo leader nella sicurezza dal 1972. Forniamo storicamente le migliori case automobilistiche con i nostri sistemi di ritenuta: dal mondo del motorsport all'industria automobilistica e all'aviazione aerospaziale. È da anni che i migliori piloti di Formula 1 come Ayrton Senna, Michael Schumacher, Lewis Hamilton, Sebastian Vettel e Daniel Ricciardo scelgono di lavorare e collaborare con noi.

Our personal history shows what we are able to be and identify what we could become. We have provided the top historical car manufacturers with innovative restraint systems for decades, combining a smart use of seat belts and seats for different applications: from the world of motorsport to the automotive industry and the aerospace. Top Formula 1 drivers past and present as Ayrton Senna, Michael Schumacher and Lewis Hamilton, Sebastian Vettel and Daniel Ricciardo have chosen to work and collaborate with us.



SAFETY



La sicurezza è di estrema importanza per Sabelt: prima in vettura, producendo le migliori cinture di sicurezza al mondo, poi per i piloti di tutte le categorie e campionati. Studiamo nuove tecnologie, nuove soluzioni e nuovi materiali: per questo, nel corso degli anni, abbiamo ampliato la nostra offerta. Oggi la Sabelt, non è più solo il leader europeo per le cinture di sicurezza da competizione, ma un'azienda capace di investire, sviluppare e produrre, accessori, abbigliamento tecnico e sedili per ogni gara automobilistica. Forniamo da anni le migliori case automobilistiche e i migliori piloti con i nostri innovativi sistemi di ritenuta e siamo gli unici in grado di testare i componenti in condizioni estreme grazie al nostro crash test dinamico avanzato sulla barriera fissa. Per raggiungere questi importanti traguardi abbiamo attrezzato laboratori tecnologicamente avanzati, accolto i migliori specialisti di settore e scelto solo i partner più affidabili.

For Sabelt, safety is of the utmost importance: first in the car, supplying the best seat belts in the world, second for drivers all over categories and championship. We develop new technologies, new solutions and new materials: that's why we have expanded our offer. Today Sabelt is not only the European leader for safety belts but it is a company able to invest, to develop and to produce accessories, fire-proof wear and seats for every type of race. We have provided the top historical car manufacturers and drivers with innovative restraint systems for decades and we are the only one able to test components at extreme conditions thanks to an internal advanced dynamic crash test. To reach so important goals, we set high technology laboratories, we receive the best specialists of this sector and we chose the most reliable partners.

DESIGN

Sabelt offre livelli di performance brillanti integrati con stile e design. Ogni componente è disegnato e ingegnato esclusivamente da Sabelt in collaborazione con centri di Design e Stile o in partnership con il cliente.

Sabelt offers high performance levels integrated with style and design. Each component is designed and engineered either exclusively by Sabelt in support with external Design&Style centres or in partnership with the client.

INNOVATION

Trasformiamo le idee in prodotti. Collaboriamo con i nostri clienti per studiare le migliori soluzioni e soddisfare nuove esigenze e necessità specifiche. Tutti i nostri prodotti sono il risultato di un processo che riunisce idee, ingegneria e tecnologia. La qualità dei prodotti Sabelt è il risultato di un'intensa ricerca e sviluppo che permette di raggiungere i più alti livelli di prestazioni e sicurezza.

We transform ideas into products. We collaborate with our customers to study new and better solutions and meet specific needs and new requirements. All our products are the result of a process that brings together various novel ideas with engineering and technology. The quality of Sabelt products is the result of intensive R&D which allows to achieve the highest levels of performance and safety.

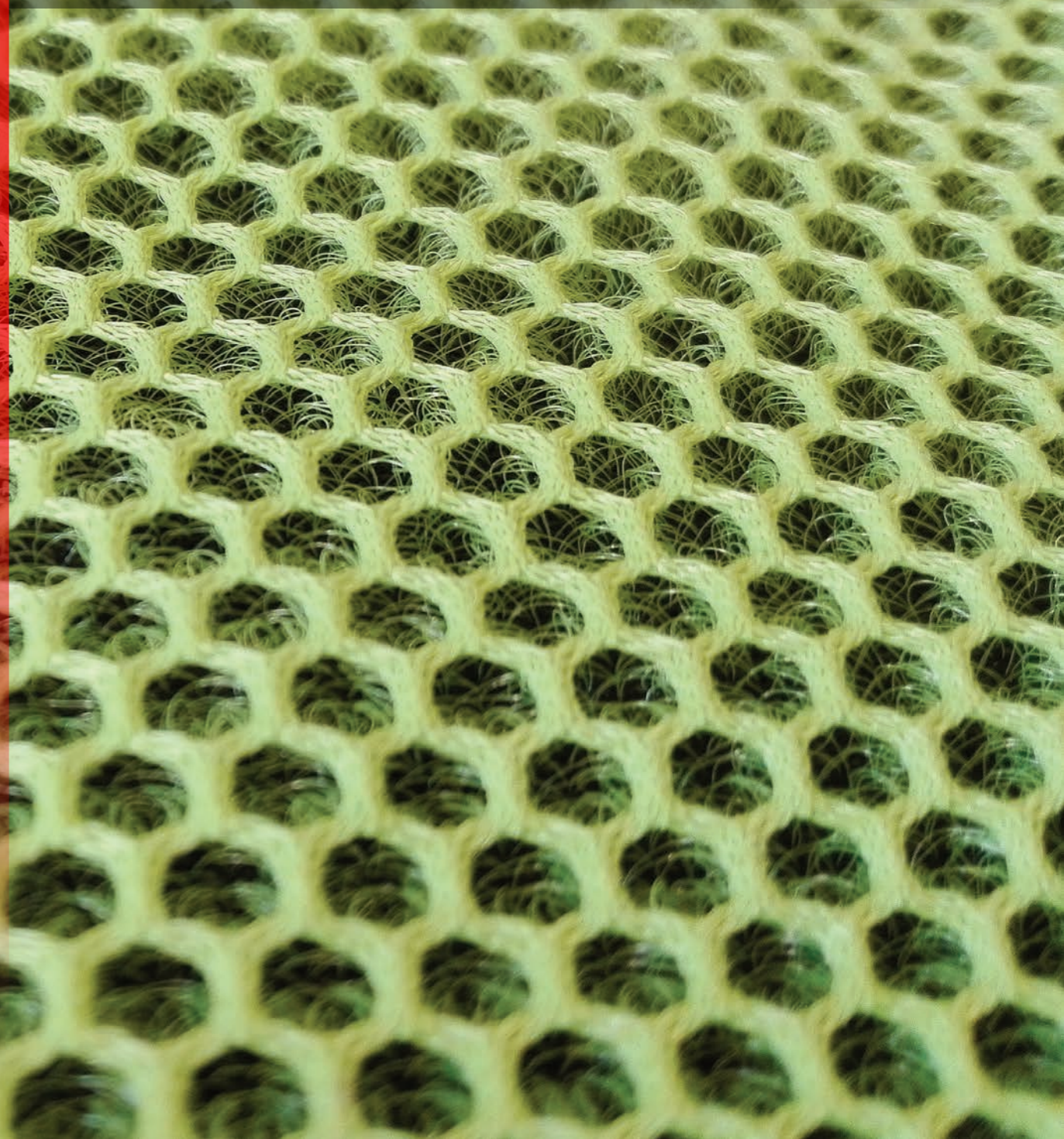

SABELT OEM

follow the sport line of excellence

Sabelt



www.sabelt.com





Sabelt ha sviluppato e implementato una nuova business unit dedicata all'applicazione di cinture in mercati di nicchia, come quello Militare, aerospaziale, dell' aviazione, dei trattori o autobus e altri mercati in cui è necessaria una personalizzazione dei prodotti. Grazie all'esperienza quarantennale nel settore e ad un laboratorio completamente attrezzato, Sabelt è capace di produrre e fornire cinture e sistemi di ritenzione omologate per molteplici applicazioni.

Sabelt has developed and implemented a new business unit dedicated to application of seatbelts in niche markets, such as Military, Aviation, Aerospace, Tractors, Bus and many fields in which small customized products for niche markets may be requested. Thanks to a long-lasting experience in this field and to a fully equipped laboratory, Sabelt is able to produce and supply safety belts for several different applications.







CINTURE
HARNESSES

GAMMA CINTURE 2018
2018 HARNESSES RANGE

SALOON

ALUMINIUM ADJUSTERS



CFCI2197_A 2 2 6



CCA622SNDN 2 2 6



CCA622SRUN1 2 2 6



CCA633RUN 3 3 6

STEEL ADJUSTERS



CCS632SRDN 3 2 6



CCS622SRUN 2 2 6



CCS633SRUN 3 3 6

STEEL ADJUSTERS



CCS433SRUN 3 3 4



shoulder (inches)
lap (inches)
fixing points

FORMULA

ALUMINIUM ADJUSTERS



CCA622FRUN 2 2 6

INDYCAR



CFCI2294 3 2 8



CFCI2339 3+2 2 6

NASCAR



CFCI2190 3+2 2 7



CFCI2256 3 2 9



CFCI2257 3+2 2 7

CLUBMAN



CFCC4046 2 2 4



904020NP 2 2 4



904070NP 2 2 4



904059NP 2 2 3



904005N 2 2 3



904019N 2 2 3

FIBBIE
BUCKLES**B1** CCFI0155

Ingressi lingue facilitati per fissaggio rapido. Alluminio ricavato dal pieno. Tongues entry designed to simplify the driver fastening. Machined from solid aluminium.

**B2** CCFI0151

Predisposizione integrata per cosciale di tipo "T". Alluminio. With integrated crotch belt "T" type attachment. Aluminium.

**B3** CCFI0160

Per cintura Formula sviluppata in F1. Protezione per leva. Alluminio. For "Formula" safety belt developed in Formula1. Aluminium. Protection for the lever. 192 g

**B4** CCFI0169

Per cintura 4 punti. Lingua fissata su ramo addominale dx. Alluminio. Buckle for 4 points safety belt. Dx fixed point. Aluminium. 184 g

LINGUE
TONGUES**T1** CCLI0001

Lingua fissaggio addominale con piega ergonomica. Acciaio. Lap belt tongue with ergonomic bend. Steel. 32 g

**T2** CCLI0002

Lingua fissaggio bretella per nastro 3". Acciaio. Shoulder belt tongue for 3" webbing. Steel. 30 g

**T3** CCLI0005_S

Lingua fissaggio bretella per nastro 2". Acciaio. Shoulder belt tongue for 2" webbing. Steel. 23 g

REGOLATORI
ADJUSTERS**A1** CCRE0023_IS

Regolatore sgancio rapido per nastro 3". Alluminio forgiato e anodizzato. Lightweight adjuster for 3" webbing. Forged and anodized aluminium. 95 g

**A2** CCRE0032_IS

Regolatore sgancio rapido per nastro 2". Alluminio forgiato e anodizzato. Lightweight adjuster for 2" webbing. Forged and anodized aluminium. 70 g

**A3** CCLI0010_A

Sgancio rapido con lingua integrata per nastro 2", per vetture GT/Endurance. Acciaio-alluminio. Adjuster integrated to the buckle tongue designed for 2" webbing. Developed for GT/Endurance cars. Steel-aluminium. 123 g

**A4** CCRE0042

Regolatore sgancio rapido per nastro 2". Acciaio-alluminio. Adjuster for 2" webbing. Steel-aluminium. 113 g

**A5** 419205M

Regolatore "America" per nastro 3". Acciaio. "America" adjuster for 3" webbing. Steel. 147 g

**A6** CCRE0041

Regolatore "America" per nastro 2". Acciaio. "America" adjuster for 2" webbing. Steel. 94 g

**A7** CCRE0008_A

Regolatore "Tribar" per nastro 3". Acciaio. "Tribar" adjuster for 3" webbing. Steel. 110 g

**A8** CCRE0009_A

Regolatore "Tribar" per nastro 2". Acciaio. "Tribar" adjuster for 2" webbing. Steel. 80 g

FISSAGGI
FIXINGS**F1** CCST0003

Carabina. Acciaio Inox. Carabinas. Inox Steel. 24 g

**F2A** CCST0019_A

Moschettone regolabile. In abbinamento con A7 o A8. Acciaio. Snap hook in combination with A7 or A8. Steel. 77 g

**F2B** CCST0019_A

Moschettone cucito. In abbinamento con A7 o A8. Acciaio. Sewn snap hook in combination with A7 or A8. Steel. 77 g

**F3A** 400793

Staffa fissaggio. In abbinamento con A7 o A8. Acciaio. Fixing plate in combination with A7 or A8. Steel. 63 g

**F3B** 400793

Staffa fissaggio cucita. In abbinamento con A7 o A8. Acciaio. Sewn fixing plate in combination with A7 or A8. Steel. 63 g

**F4** CCST0008

Staffa fissaggio. Acciaio. Fixing plate. Steel. 44 g

**F5** Wrap around

"Loop" regolabile per fissaggio a Rollbar. In abbinamento con A7 o A8. "Wrap around" fixing in combination with A7 or A8.

**F6** Sewn loop

"Loop" fisso, cucito, per fissaggio a Rollbar. "Sewn loop" fixing.

OPTIONALS

**O1** CCL10010_A

Etichetta logo/advertising cucita. Sewn logo/advertising label.

**O2** CCL10010_A

Stampa logo/advertising in materiale alto grip per FHR. Logo/advertising printed directly on the webbing in high grip material for FHR.

**O3** CCL10010_A

Cordino per fissaggio intercom o drink system. Intercom or Drink System cord.

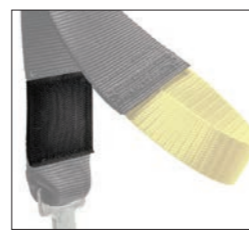
**O4** CCL10010_A

Velcro per chiusura nastri parte regolabile. Closure velcro for adjustable straps.

**O5** CCL10010_A

Maniglie ergonomiche. Ergonomic handle.

CFCI2197_A

STANDARD FEATURES

FIA 8853-2016

SALOON

NEW



STANDARD CODES

■ RED CFCI0197_A

■ BLACK CFCI02197_A

STANDARD MEASURES (mm)

A 360

B 1700

C 720

D 390

- Bretelle tutta 2" - regolatore alluminio alleggerito
- Fissaggio bretella tribar
- Addominale tutto 2" - attacco specifico
- Regolatore integrato alla lingua con configurazione Pull Down. Tipico per vetture GT/Endurance
- Nuova fibbia progettata per essere compatta
- Cosciali integrati al corpo principale
- Cosciali 2" attacco moschettone - tribar
- Maniglie gialle

- Shoulder straps: full 2" width - aluminum lightweight adjuster
- Shoulder fixing: tribar
- Lap belts: full 2" width - specific fixing
- Lap belts: 2" quick adjuster integrated to buckle tongue - Pull Down. Designed for GT/ Endurance
- New compact buckle designed with crotches
- Crotches: 2" width - snap hook / tribar fixing
- Yellow loops

CFCI2197_A

CONFIGURATIONS ON DEMAND

i PER MAGGIORI INFORMAZIONI E CODICI VEDERE PAG. 16-17
FOR FURTHER INFORMATIONS AND CODES SEE PAGES 16-17

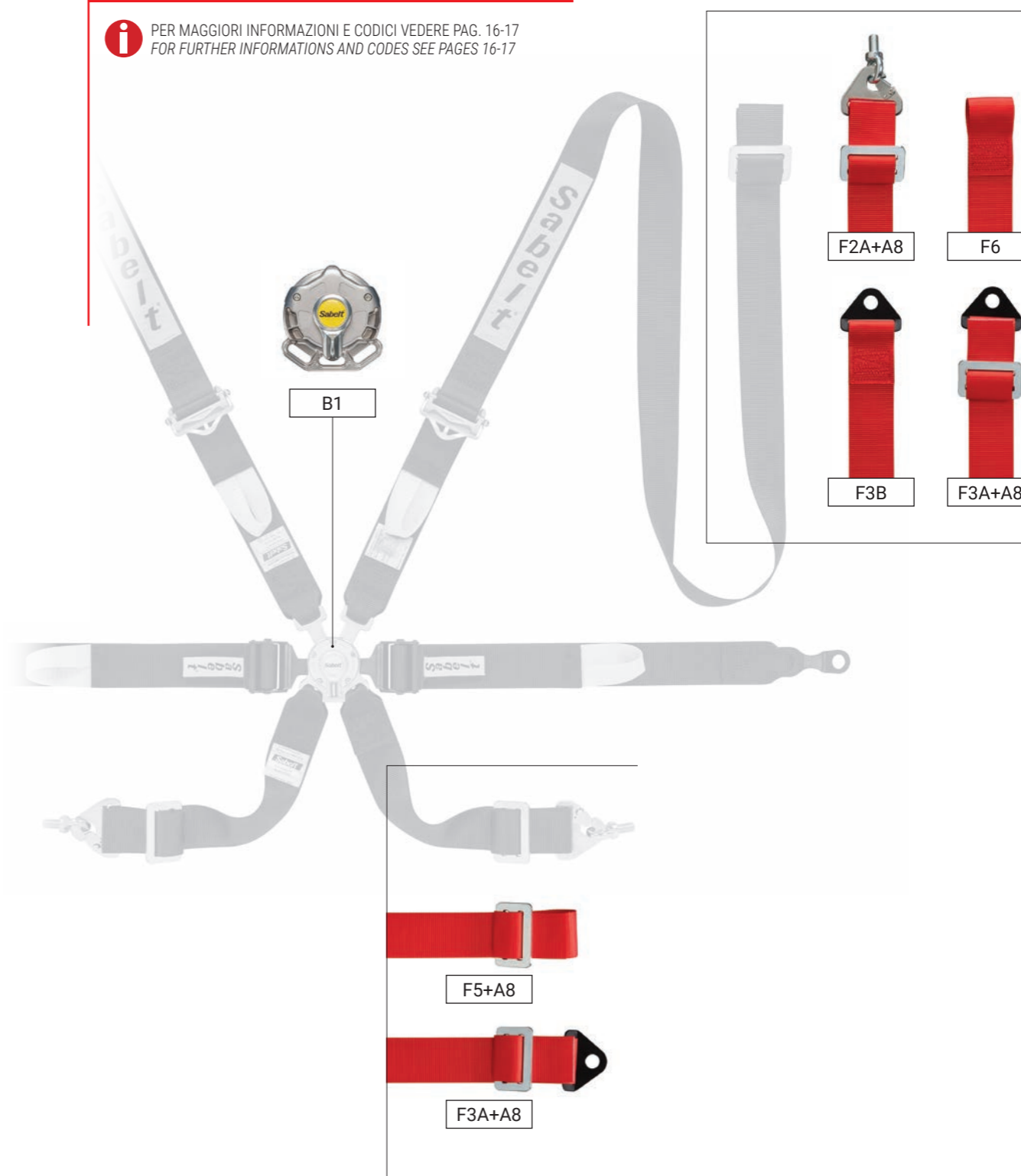

OPTIONALS

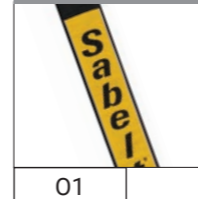

01



02



03

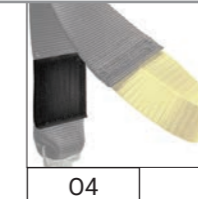

04

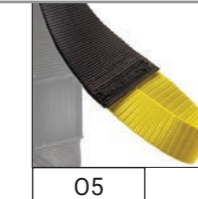

05

CCA622SRDN

STANDARD FEATURES

FIA 8853-2016

SALOON

NEW



STANDARD CODES

RED	CCA622SRDN
BLACK	CCA622SNDN
BLUE	CCA622SBDN

STANDARD MEASURES (mm)

A	380
B	1700
C	680
D	850

- Bretelle tutta 2" - regolatore alluminio alleggerito
- Fissaggio bretella moschettone - tribar
- Addominale tutto 2" - attacco carabina
- Regolatore integrato alla lingua con configurazione Pull Down. Tipico per vetture GT/Endurance
- Nuova fibbia progettata per essere compatta
- Cosciali integrati al corpo principale
- Cosciali 2" attacco moschettone - tribar
- Maniglie gialle
- Velcro sulle bretelle
- Nastro per fissaggio intercom su bretella

- Shoulder straps: full 2" width - aluminum lightweight adjuster
- Shoulder fixing: snap hook - tribar
- Lap belts: full 2" width - lightweight carabinas
- Lap belts: 2" quick adjuster integrated to buckle tongue - Pull Down. Designed for GT/Endurance
- New compact buckle designed with crotches slots integrated to main body
- Crotches: 2" width - snap hook / tribar fixing
- Yellow loops
- Velcros on shoulders
- Intercom wire fixing

CCA622SNDN

CONFIGURATIONS ON DEMAND

i PER MAGGIORI INFORMAZIONI E CODICI VEDERE PAG. 16-17
FOR FURTHER INFORMATIONS AND CODES SEE PAGES 16-17

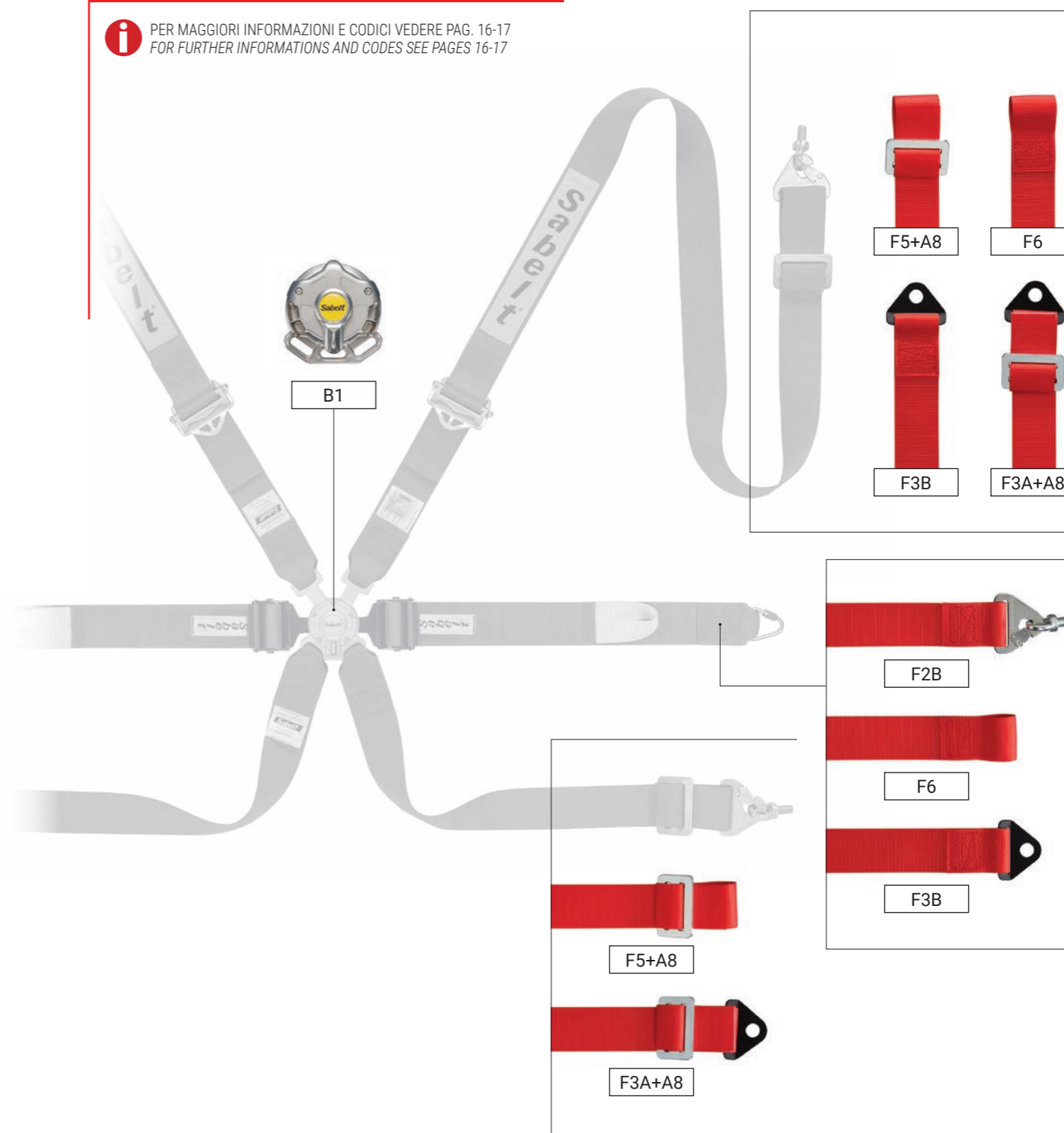

OPTIONALS

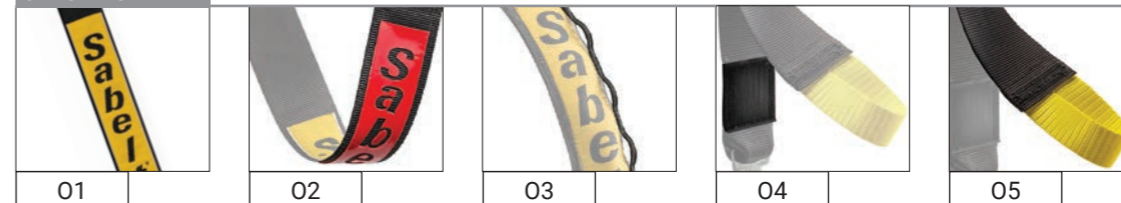

CCA622SRUN1

STANDARD FEATURES

FIA 8853-2016

SALOON

NEW

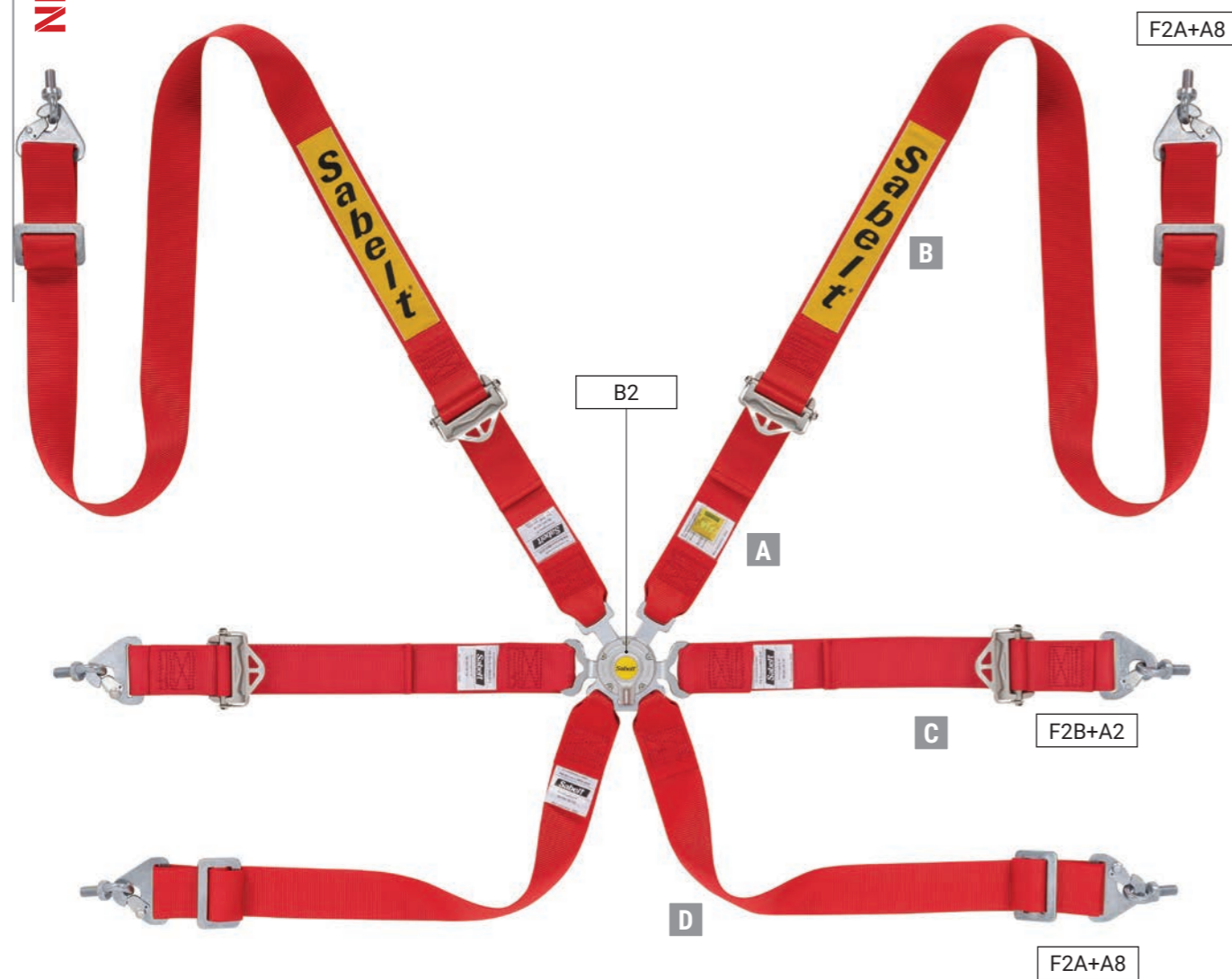

STANDARD CODES

RED	CCA622SRUN1
BLACK	CCA622SNUN1
BLUE	CCA622SBUN1

STANDARD MEASURES (mm)

A	380
B	1700
C	560 + 120
D	850

- Bretelle tutta 2" - regolatore alluminio alleggerito
- Fissaggio bretella moschettone - tribar
- Addominale tutto 2" - regolatore alluminio alleggerito Pull Up - attacco moschettone
- Nuova fibbia progettata per essere compatta
- Cosciali integrati al corpo principale
- Cosciali 2" attacco moschettone - tribar

- Shoulder straps: full 2" width - aluminum lightweight adjuster
- Shoulder fixing: snap hook - tribar
- Lap belts: full 2" width - aluminum lightweight adjuster Pull Up - snap hook fixing
- New compact buckle designed with crotches slots integrated to main body
- Crotches: 2" width - snap hook / tribar fixing

CCA622SRUN1

CONFIGURATIONS ON DEMAND

i PER MAGGIORI INFORMAZIONI E CODICI VEDERE PAG. 16-17
FOR FURTHER INFORMATIONS AND CODES SEE PAGES 16-17

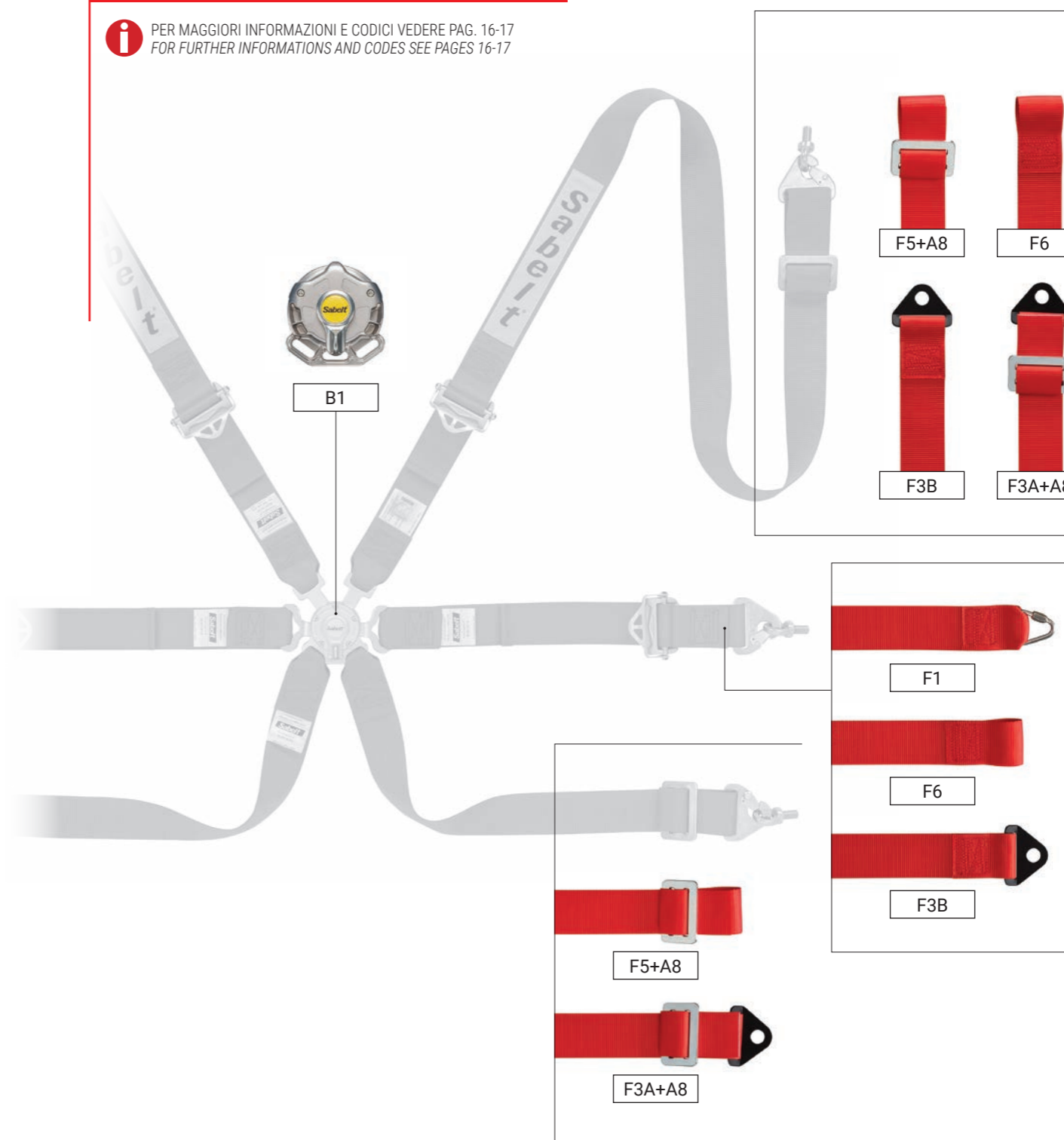

OPTIONALS



CCA633SRUN

STANDARD FEATURES

FIA 8853-2016

SALOON

NEW



STANDARD CODES

RED CCA633SRUN

BLACK CCA633SNUN

BLUE CCA633SBUN

STANDARD MEASURES (mm)

A 380

B 1700

C 560 + 120

D 850

- Bretelle tutta 3" - regolatore alluminio alleggerito
- Fissaggio bretella moschettone - tribar
- Addominale tutto 3" - regolatore alluminio alleggerito Pull Up - attacco moschettone
- Nuova fibbia progettata per essere compatta
- Cosciali integrati al corpo principale
- Cosciali 2" attacco moschettone - tribar

- Shoulder straps: full 3" width - aluminum lightweight adjuster
- Shoulder fixing: snap hook - tribar
- Lap belts: full 3" width - aluminum lightweight adjuster Pull Up-snap hook fixing
- New compact buckle designed with crotches slots integrated to main body
- Crotches: 2" width - snap hook / tribar fixing

CCA633SRUN

CONFIGURATIONS ON DEMAND

i PER MAGGIORI INFORMAZIONI E CODICI VEDERE PAG. 16-17
FOR FURTHER INFORMATIONS AND CODES SEE PAGES 16-17

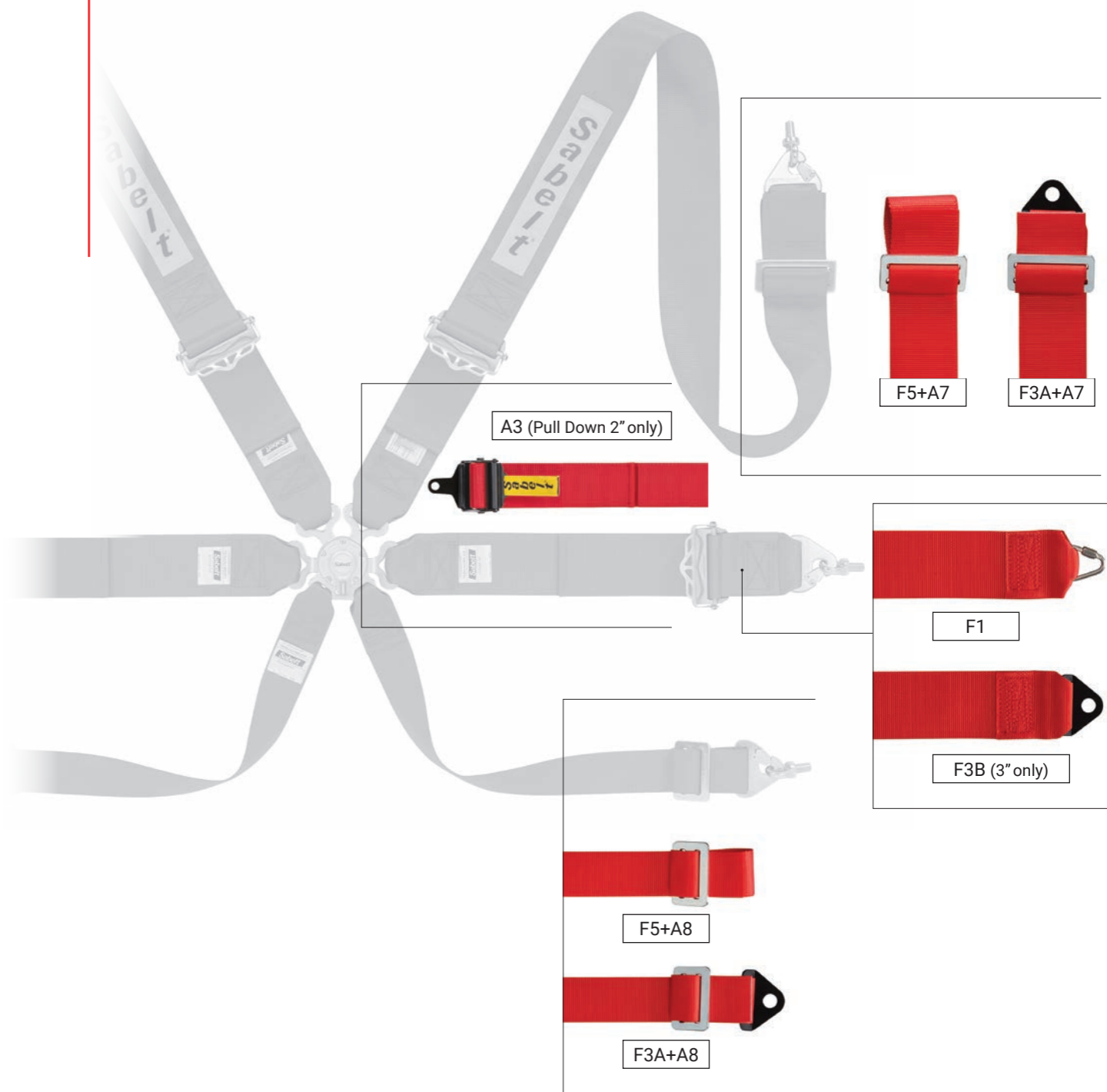

OPTIONALS



01



02

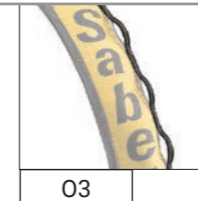

03

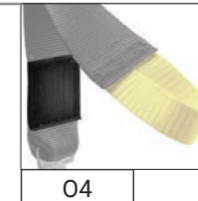

04

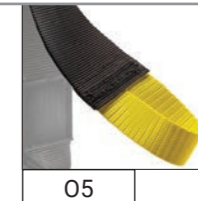

05

CCA622FRUN

STANDARD FEATURES

FIA 8853-2016

FORMULA

NEW



STANDARD CODES

RED CCA622FRUN

BLACK CCA622FNUN

BLUE CCA622FBUN

STANDARD MEASURES (mm)

A 440

B 900

C 530 + 120

D 1200

- Bretelle tutta 2" - regolatore alluminio alleggerito
- Fissaggio bretella piastra - tribar
- Addominale tutto 2" - regolatore acciaio/ alluminio Pull Up - attacco piastra
- Nuova fibbia progettata per essere compatta
- Cosciali tipo "formula"
- Cosciali 2" attacco piastra - tribar

- Shoulder straps: full 2" width - aluminum lightweight adjuster
- Shoulder fixing: plate - tribar
- Lap belts: full 2" width - steel/aluminum adjuster Pull Up - plate fixing
- New compact buckle
- Crotches: "formula" type 2" width - plate / tribar fixing

CCA622FRUN

CONFIGURATIONS ON DEMAND

i PER MAGGIORI INFORMAZIONI E CODICI VEDERE PAG. 16-17
FOR FURTHER INFORMATIONS AND CODES SEE PAGES 16-17

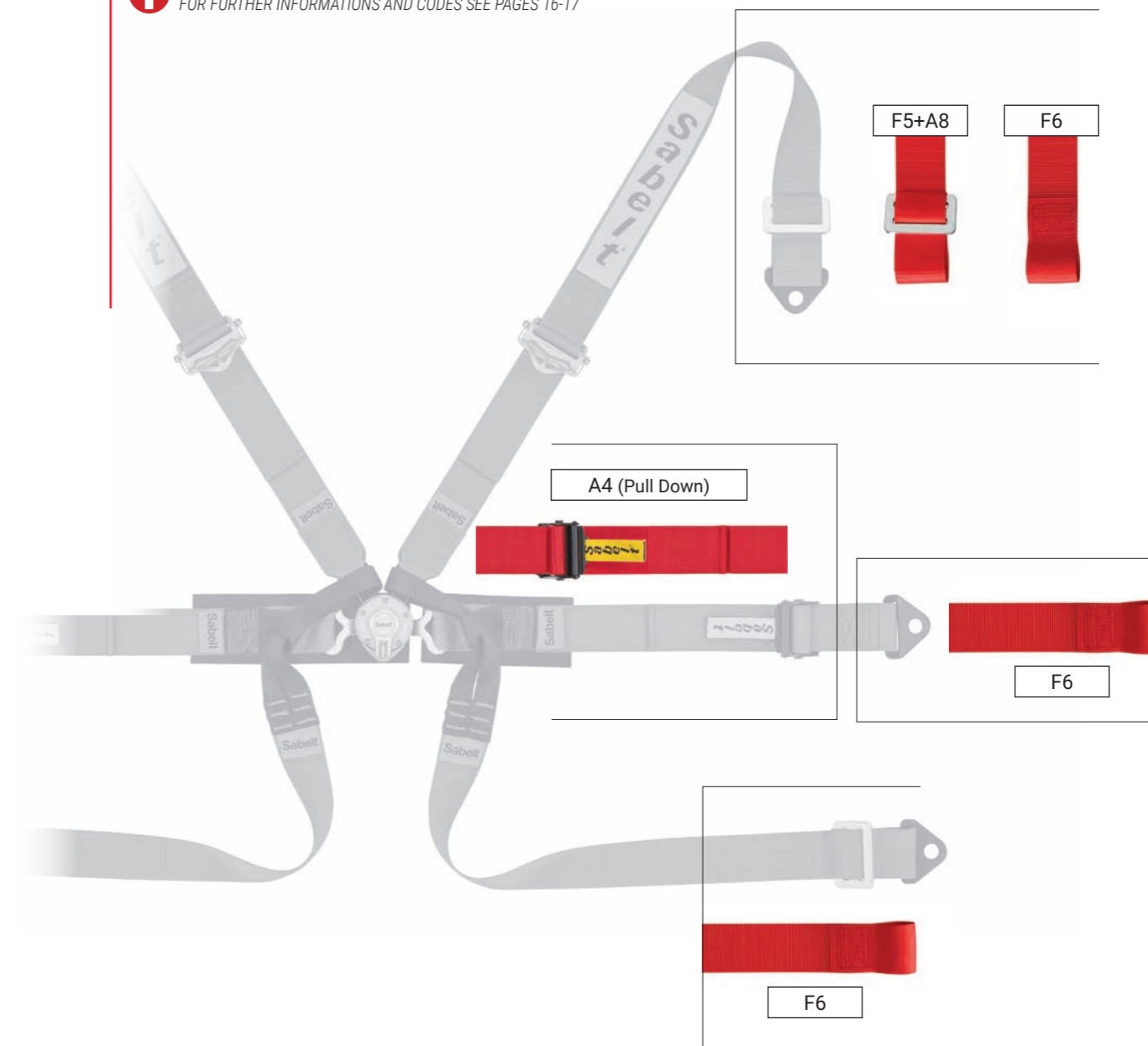

OPTIONALS

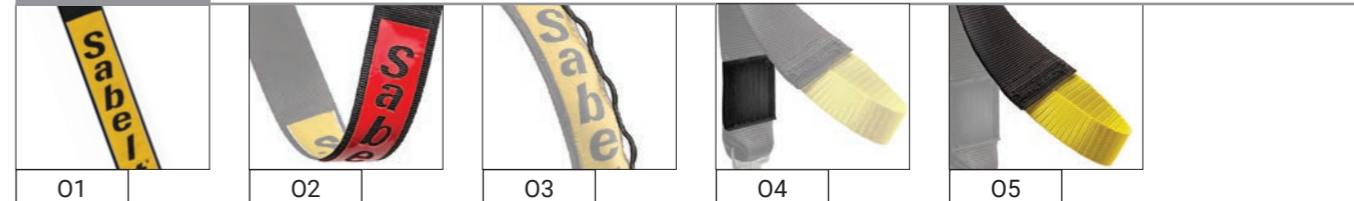

CCS632SRDN

STANDARD FEATURES

FIA 8853-2016

SALOON

NEW



STANDARD CODES

RED CCS632SRDN

BLACK CCS632SNDN

BLUE CCS632SBDN

STANDARD MEASURES (mm)

A 380

B 1700

C 680

D 850

- Bretelle tutta 3" - regolatore acciaio
- Fissaggio bretella moschettone - tribar
- Addominale tutto 2" - attacco moschettone
- Regolatore integrato alla lingua con configurazione Pull Down. Tipico per vetture GT/Endurance
- Nuova fibbia progettata per essere compatta
- Cosciali integrati al corpo principale
- Cosciali 2" attacco moschettone - tribar

- Shoulder straps: full 3" width - steel adjuster
- Shoulder fixing: snap hook - tribar
- Lap belts: full 2" width - snap hook
- Lap belts: 2" quick adjuster integrated to buckle tongue - Pull Down. Designed for GT/Endurance
- New compact buckle designed with crotches slots integrated to main body
- Crotches: 2" width - snap hook / tribar fixing

CCA632SRDN

CONFIGURATIONS ON DEMAND

i PER MAGGIORI INFORMAZIONI E CODICI VEDERE PAG. 16-17
FOR FURTHER INFORMATIONS AND CODES SEE PAGES 16-17

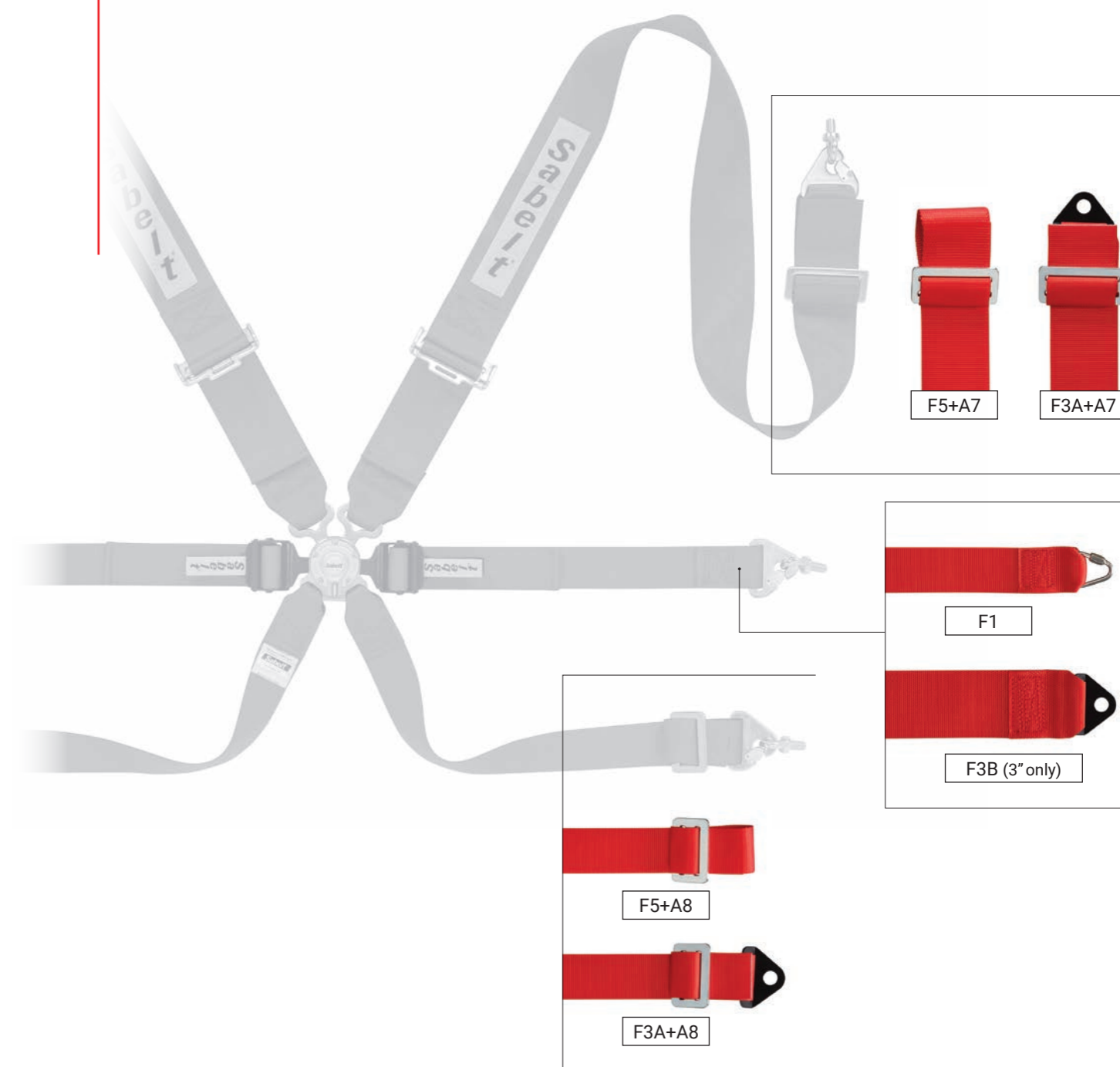

CCS622SRUN

STANDARD FEATURES

FIA 8853-2016

SALOON

NEW

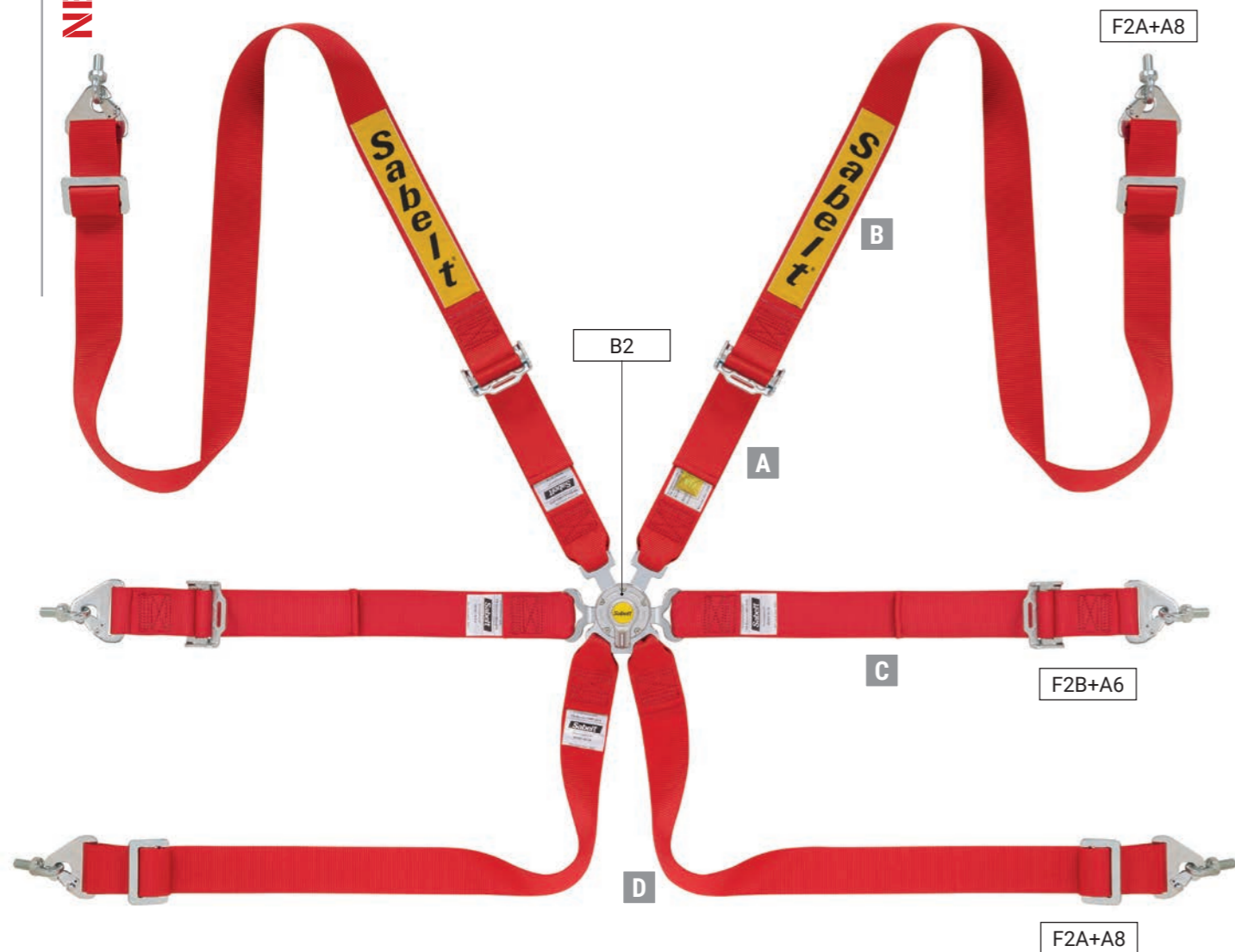

STANDARD CODES

■ RED CCS622SRUN

■ BLACK CCS622SNUN

■ BLUE CCS622SBUN

STANDARD MEASURES (mm)

A	380
B	1700
C	560 + 120
D	850

- Bretelle tutta 2" - regolatore acciaio
- Fissaggio bretella moschettone - tribar
- Addominale tutto 2" - regolatore acciaio Pull Up - attacco moschettone
- Nuova fibbia progettata per essere compatta
- Cosciali integrati al corpo principale
- Cosciali 2" attacco moschettone - tribar

- Shoulder straps: full 2" width - steel adjuster
- Shoulder fixing: snap hook - tribar
- Lap belts: full 2" width - steel adjuster Pull Up - snap hook fixing
- New compact buckle designed with crotches slots integrated to main body
- Crotches: 2" width - snap hook / tribar fixing

CCS622SRUN

CONFIGURATIONS ON DEMAND

i PER MAGGIORI INFORMAZIONI E CODICI VEDERE PAG. 16-17
FOR FURTHER INFORMATIONS AND CODES SEE PAGES 16-17

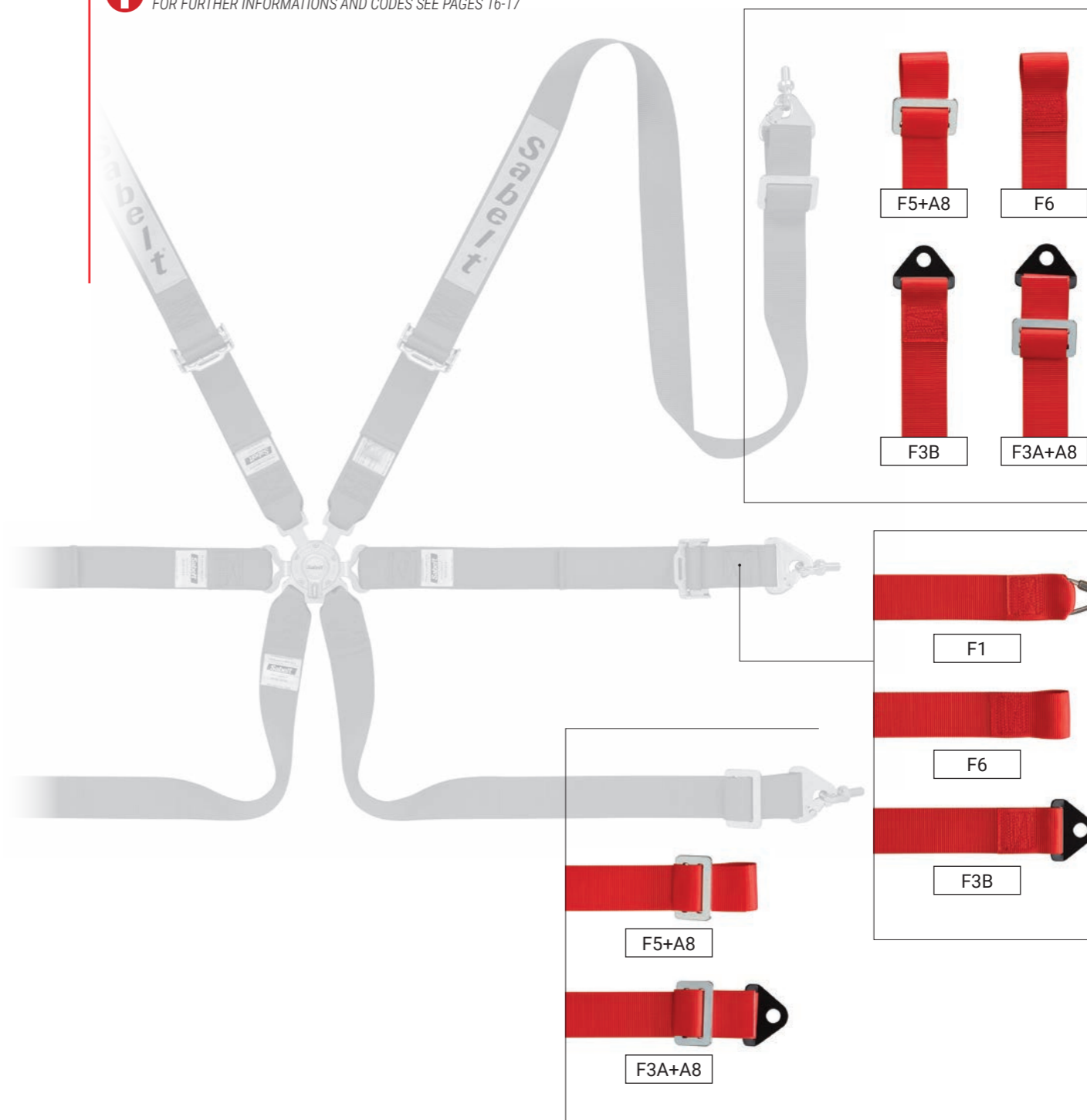

CCS633SRUN

STANDARD FEATURES

FIA 8853-2016

SALOON

NEW



STANDARD CODES

RED	CCA633SRUN
BLACK	CCA633SNUN
BLUE	CCA633SBUN

STANDARD MEASURES (mm)

A	380
B	1700
C	560 + 120
D	850

- Bretelle tutta 3" - regolatore acciaio
- Fissaggio bretella moschettone - tribar
- Addominale tutto 3" - regolatore acciaio Pull Up - attacco moschettone
- Nuova fibbia progettata per essere compatta
- Cosciali integrati al corpo principale
- Cosciali 2" attacco moschettone - tribar

- Shoulder straps: full 3" width - steel adjuster
- Shoulder fixing: snap hook - tribar
- Lap belts: full 3" width - steel adjuster Pull Up - snap hook fixing
- New compact buckle designed with crotches slots integrated to main body
- Crotches: 2" width - snap hook / tribar fixing

CCS633SRUN

CONFIGURATIONS ON DEMAND

i PER MAGGIORI INFORMAZIONI E CODICI VEDERE PAG. 16-17
FOR FURTHER INFORMATIONS AND CODES SEE PAGES 16-17

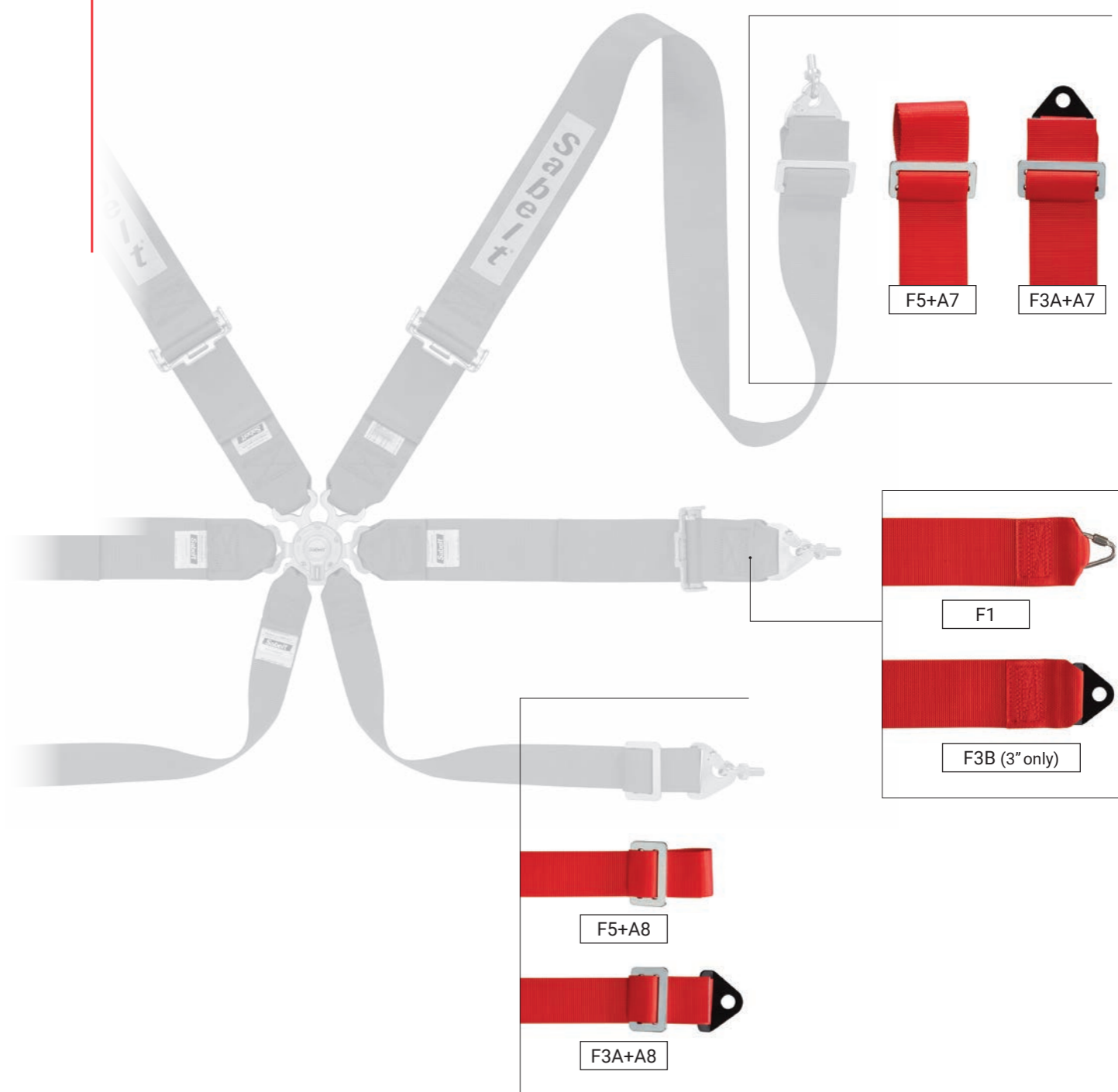

CCS433SRUN

STANDARD FEATURES

FIA 8854/98

SALOON



STANDARD CODES

RED	CCA433SRUN
BLACK	CCA433SNUN
BLUE	CCA433SBUN

STANDARD MEASURES (mm)

A	380
B	1700
C	560 + 120

- Bretelle tutta 3" - regolatore acciaio
- Fissaggio bretella moschettone - tribar
- Addominale tutto 3" - regolatore acciaio Pull Up - attacco moschettone
- Fibbia fissata su ramo addominale dx

- Shoulder straps: full 3" width - steel adjuster
- Shoulder fixing: snap hook - tribar
- Lap belts: full 3" width - steel adjuster Pull Up - snap hook fixing
- Buckle fixed to dx lap belt

COSCIALI - CROTCH STRAPS

Per convertire cinture 4 punti omologate Fia 8854/98 a 6 punti Fia 8853/98. **Attenzione:** possono essere convertite cinture 4 punti con scadenza massima "Not valid after 2022" prodotte fino al 2017. Le cinture 4 punti prodotte a partire dal 2018 non possono essere convertite. To upgrade 4-point Belts 8854/98 to 6-Point 8853/98. **Warning:** only until "Not valid after 2022" produced until 2017 can be converted. The 4-point belts produced since 2018 cannot be converted.



MODELLO T - Cosciale con 2 punti di fissaggio a moschettoni, golfari a filetto 7/16" inclusi, nastro da 2", con regolatore per la lunghezza. Mini baffo anatomico. Adattabile a tutta la gamma per berlina.

T-TYPE - T-type crotch strap. Snap hook fixing with 7/16" eyebolt included. Adjustable length. New anatomical T-bar. 2" webbing. Fits to all Sabelt range of harnesses for saloon cars.

RED	414850E
BLACK	412850E
BLUE	411850E



MODELLO A V IMBULLONATO - Cosciale con 2 punti di fissaggio imbullonati e minilingua. Nastro da 2", munito di regolatore per la lunghezza. Adattabile a tutta la gamma Sabelt per berlina.

BOLT-IN V-TYPE - V-type crotch strap bolt-in. 2" webbing, adjustable length. Fits to all Sabelt range of harnesses for saloon cars.

RED	414853E
BLACK	412853E
BLUE	411853E



MODELLO A V CON MOSCHETTONI - Cosciale con 2 punti di fissaggio a moschettoni, golfari a filetto 7/16" inclusi. Nastro da 2" con regolatore per la lunghezza. Adattabile a tutta la gamma Sabelt per berlina.

SNAP HOOK V-TYPE - V-type crotch strap. Snap hook fixing with 7/16" eyebolt included. 2" webbing adjustable length. Fits to all Sabelt range of harnesses for saloon cars.

RED	414853ME
BLACK	412853ME
BLUE	411853ME

GOLFARI E PIASTRE - EYE BOLTS AND PLATES



407005

Vite ad occhio standard diam. 7/16" filetto UNF, lungh. filetto 23 mm, lungh. totale 25 mm. Classe di resistenza 8.8.

Standard eye-bolt diam. 7/16" UNF thread length 23 mm, 25 mm tot., 8.8.



CCMi0018

Vite ad occhio diam. 7/16" UNF, lungh. filetto 32 mm, classe di resistenza 8.8.

Eye-bolt 7/16" UNF, thread length 32 mm, 8.8.



CCMi0023

Vite ad occhio a filetto metrico M10 x 1,5 lungh. 23 mm classe di resistenza 8.8. Non conforme FIA.

Eye-bolt metric M10 x 1.5 thread length 23 mm, 8.8. Does not comply with FIA requirements.



CCMi0017 - WESTFIELD

Vite ad occhio lungh. 50 mm, diam. 7/16", classe di resistenza 8.8.

Eye-bolt 50 mm. long, 7/16", 8.8.



CCMi0016

Piastra di rinforzo per vite ad occhio 7/16" filetto UNF con dado saldato misura 65 x 65 x 3 mm a norma FIA (superficie 40 mm²).

Eye-bolt back plate 65 mm x 65 mm x 3 mm 7/16" UNF thread welded nut, 40 mm². Complies with FIA requirements.

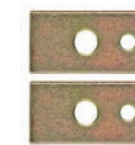

SB/2049

Piastra di rinforzo 50 x 25 x 6 mm, 7/16" filetto UNF. Non conforme FIA.

Eye bolt back plate 50 x 25 mm, 6 mm thick, 7/16" UNF thread. Does not comply with FIA requirements.



Coprispalla in tessuto Vep. Largh. 75 mm (3"). Chiusura con velcro. Vep fabric shoulder cover. 75 mm (3") width. Velcro fastening.

RED	475040
BLACK	475020
BLUE	475010



Coprispalla in tessuto Vep. Largh. 50 mm (2"). Chiusura con velcro. Vep fabric shoulder cover. 50 mm (2") width. Velcro fastening.

RED	450040
BLACK	450020
BLUE	450010

INDYCAR

NEW

CFCI2294

STANDARD CODES

BLACK CFCI2294

STANDARD MEASURES (mm)

A	280
B3	(3") 430
B2	(2") 510 + 100
C	550
D	990

- SF116.5 Formula style (Indycar)
- Doppia bretella
- Fissaggio bretella 3" loop cucito
- Fissaggio bretella 2" regolabile pull down
- Regolatore alluminio quick release 3" su bretelle
- Addominali regolabili con tribar
- Fissaggio addominali staffa
- Cosciali formula con attacco staffa e stop

- SF116.5 Formula style (Indycar)
- Double shoulder
- Shoulder 3": sewn loop
- Shoulder 2": sewn loop adjustable pull down
- Quick release 3" aluminum adjusters on shoulders
- Adjustable lap w/tribars
- Lap belts Bolt in fixing
- Formula style crotches bolt in and stop



NEW

CFCI2339

STANDARD CODES

BLACK CFCI2339

STANDARD MEASURES (mm)

A	280
B	510
C	550
D	990

- SF116.5 Formula style (Indycar)
- Bretelle singole 3+2
- Attacco bretelle: loop cucito o wrap around
- Regolatori alluminio 3"
- Addominali regolabili con tribar
- Fibbia leva piatta
- Cosciali formula con attacco staffa e stop

- SF116.5 Formula style (Indycar)
- 3+2 shoulder belts
- Shoulder fixing: sewn loop or wrap around
- Quick release 3" aluminum adjusters on shoulders
- Adjustable lap w/tribars
- Flat lever camlock
- Formula style crotches bolt in and stop



NASCAR

NEW

CFCI2190

STANDARD CODES

BLACK CFCI2190

STANDARD MEASURES (mm)

A	406	D	766
B	726	Neg G	-
C	838		

- SF116.6 NASCAR • Bretelle singole 3+2
- Attacco bretelle wrap around • Regolatori alluminio 3"
- Addominali regolabili con tribar
- Cosciali formula con attacco staffa e stop
- Negative G belt attacco doppia piastra

- SF116.6 NASCAR • 3+2 shoulder belts
- Shoulder fixing: wrap around • Quick release 3" aluminum adjusters on shoulders
- Adjustable lap w/tribars • Formula style crotches bolt in and stop
- Negative G belt double bolt in



NEW

CFCI2256

STANDARD CODES

BLACK CFCI2256

STANDARD MEASURES (mm)

A	280	C	550
B3	455	D	650
B2	100 + 400	Neg G	508

- SF116.6 NASCAR • Doppia bretella • Fissaggio bretella 3" wrap around
- Fissaggio bretella 2" wrap around pull up
- Regolatore alluminio quick release 3" and 2" su bretelle
- Addominali regolabili pull down lingua regolabile integrata
- Fissaggio addominali staffa • Cosciali T-bar style attacco staffa + tribar
- Negative G belt attacco doppia piastra

- SF116.6 NASCAR • Double shoulder
- Shoulder 3": wrap around • Shoulder 2": wrap around pull up
- Quick release 3" and 2" aluminum adjusters on shoulders
- double pull down lap, 2" quick release adjuster integrated to camlock
- Lap belts Bolt in fixing • T-bar crotches style bolt in + tribar
- Negative G belt double bolt in



NEW

CFCI2257

STANDARD CODES

BLACK CFCI2257

STANDARD MEASURES (mm)

A	350	D	760
B	815	Neg G	736
C	790		

- SF116.6 NASCAR • Bretelle singole 3+2 • Attacco bretelle wrap around
- Regolatori alluminio 3" • Cosciali T-bar style attacco staffa + tribar
- Addominali regolabili pull down lingua regolabile integrata
- Negative G belt attacco doppia piastra

- SF116.6 NASCAR • 3+2 shoulder belts • Shoulder fixing: wrap around
- Quick release 3" aluminum adjusters on shoulders
- double pull down lap, 2" quick release adjuster integrated to camlock
- T-bar crotches style bolt in + tribar • Negative G belt double bolt in



CLUBMAN

CFCC4046

SALOON
4 Fixing points

STANDARD CODES
■ RED CFCC4046
■ BLACK CFCC2046
■ BLUE CFCC1046



904020NP

SALOON
4 Fixing points
ECE

STANDARD CODES
■ RED 904020NP
■ BLACK 902020NP
■ BLUE 901020NP
■ GREY 907020NP



Coppia cuscinetti coprispalla inclusa. Pair of shoulder pads included.



904070NP

SALOON
4 Fixing points
ECE

STANDARD CODES
■ RED 904070NP
■ BLACK 902070NP
■ BLUE 901070NP
■ GREY 907070NP



Coppia cuscinetti coprispalla inclusa. Pair of shoulder pads included.



904059NP

SALOON
3 Fixing points
ECE

STANDARD CODES
■ RED 904059NP
■ BLACK 902059NP
■ BLUE 901059NP
■ GREY 907059NP



Coppia cuscinetti coprispalla inclusa. Pair of shoulder pads included.



904005N

SALOON
3 Fixing points
ECE

STANDARD CODES
■ RED 904005N
■ BLACK 902005N
■ BLUE 901005N
■ GREY 907005N



904019N

SALOON
3 Fixing points
ECE

STANDARD CODES
■ RED 904019N
■ BLACK 902019N
■ BLUE 901019N
■ GREY 907019N



SEDILI SEAT'S



ACCESSORI E RICAMBI PER SEDILI - SEATS ACCESSORIES AND SPARES

**S1**Schienale sedile sp. 20 mm
Seatback cushion th. 20 mm

TITAN	RRTITAU002
TITAN MAX	RRTITAU003
TAURUS	RRTITAU002
TAURUS MAX	RRTITAU003

CUSCINI - CUSHIONS

**CS1**Cuscino seduta sp. 20 mm
Lower cushion th. 20 mm

TITAN	RRTITAU004
TITAN MAX	RRTITAU007
TAURUS	RRTITAU004
TAURUS MAX	RRTITAU007

**CS2**Cuscino seduta sp. 40 mm
Lower cushion th. 40 mm

TITAN	RRTITAU005
TITAN MAX	RRTITAU008
TAURUS	RRTITAU005
TAURUS MAX	RRTITAU008

**CS3**Cuscino seduta sp. 50 mm
Lower cushion th. 50 mm

TITAN	RRTITAU006
TITAN MAX	RRTITAU009
TAURUS	RRTITAU006
TAURUS MAX	RRTITAU009

CUSCINI - CUSHIONS

**PG1**Poggiagambe sp. 40 mm
Leg cushion th. 40 mm

TITAN	RRTITAU010
TITAN MAX	RRTITAU012
TAURUS	RRTITAU010
TAURUS MAX	RRTITAU012

**PG2**Poggiagambe sp. 50 mm
Leg cushion th. 50 mm

TITAN	RRTITAU011
TITAN MAX	RRTITAU013
TAURUS	RRTITAU011
TAURUS MAX	RRTITAU013

**CPR** RRTITAU014Coppia poggireni laterali
Lower back support**CL** RRTITAU001Cuscino supporto lombare
Lumbar support

STAFFE DI FISSAGGIO - FIXING FRAMES

**F1** Z200087Attacco laterale in acciaio alto
resistenziale, sp. 3 mm,
conforme FIA.
Steel brackets, th. 3mm, in
compliance with FIA.**F2** Z200058Attacco laterale in alluminio,
sp. 5 mm, conforme FIA.
Aluminium brackets, th. 5 mm,
in compliance with FIA.**F3** Z200002Guide scorrevoli, corsa 230 mm
Sliders, travel 230 mm**F4** RCST635FIXAttacchi laterali in acciaio per GT-635,
omologazione Fia. Note: Specificare la
taglia del sedile al momento dell'ordine.
Steel brackets for GT-635, Fia homologated.
Note: Specify the seat size during the order.**F5**Guide scorrevoli per GT-635.
Sliders for GT-635.

Size M	RFST635SLIDINGM
Size L / XL	RFST635SLIDINGXL

**F6** XRFST0007Attacco laterale in acciaio per
GT-621, omologazione FIA.
Steel brackets for GT-621, FIA
homologated.**F7** RA8862019Guide scorrevoli per GT-625.
Sliders for GT-625.

KIT - SET

**KIT KF**Kit fodera sedile.
Seat cover kit.

GT-621 Size M	RRGT621019
GT-621 Size L	RRGT621020
GT-625 Size L	RRGT625018
GT-635 Size M	RRGT635015
GT-635 Size L	RRGT635016
GT-635 Size XL	RRGT635017

**KIT KFP**Kit fodera sedile con mostrine
passacintura.
Seat cover kit with bezels.

TITAN	RRTITAN021
TITAN MAX	RRTITAN022
TITAN CARBON	RRTITCAR026
TITAN MAX CARBON	RRTITCAR027
TAURUS M	RRTAURUS023
TAURUS	RRTAURUS024
TAURUS MAX	RRTAURUS025

PASSA CINTURE - BEZELS

**KIT KP** RRCBO028Kit plastiche passa cintura per
sedili FIA 8855.
Bezels for 8855 seats.**MP** RCBO0011Mostrina passa cintura per sedili
GT-635 e GT-625.
Bezel for GT-635 and GT-625.

LEGENDA TABELLA MISURE SEDILI - LEGEND SEAT DIMENSIONS CHART

DIMENSIONI SCOCCA - SHELL DIMENSIONS (mm)

A	Profondità - Length
B	Altezza - Height
C	Larghezza altezza spalle - External shoulder width
D	Larghezza seduta anteriore - External lower frontal width
E	Larghezza seduta posteriore - External lower rear width
F	Interasse fori di fissaggio laterale - Lateral interaxis distance
♣	Peso scocca - Shell weight (kg) - Shell weight (kg)

DIMENSIONI INTERNE SEDILE - INTERNAL SEAT DIMENSIONS (mm)

G	Larghezza cuscino posteriore - Rear lower cushion width
H	Larghezza cuscino anteriore - Frontal lower cushion width
I	Larghezza altezza spalle - Internal shoulder width
L	Larghezza centro schienale - Central seatback width
M	Larghezza contenimento testa - Internal head protection width
N	Altezza passa cintura - Central bezel height
♣	Peso sedile - Seat weight (kg)

GT-635

NEW



SIZE	M (GT-635 M)	L (GT-635 L)	XL (GT-635 XL)
CODE	RFSEGT635MN	RFSEGT635N	RFSEGT635XLN



HOMOLOGATION **FIA 8862-2009**

Il nuovo sedile GT-635 è stato sviluppato per uso Circuito e Rally. La scocca, disponibile in due taglie è frutto di un approfondito studio di ergonomia atto ad assicurare la migliore posizione di guida per il pilota. Il fondo piatto e l'inclinazione dello schienale favoriscono un posizionamento ottimale in vettura.

The GT-635 have been designed for Circuit and Rally. The shell is the result of accurate ergonomical studies aimed to ensure optimal position for the driver. The flat shape bottom and the specific back inclination design provide an excellent position in the car.



i PER MAGGIORI INFORMAZIONI E CODICI VEDERE PAG. 42-43
FOR FURTHER INFORMATIONS AND CODES SEE PAGES 42-43

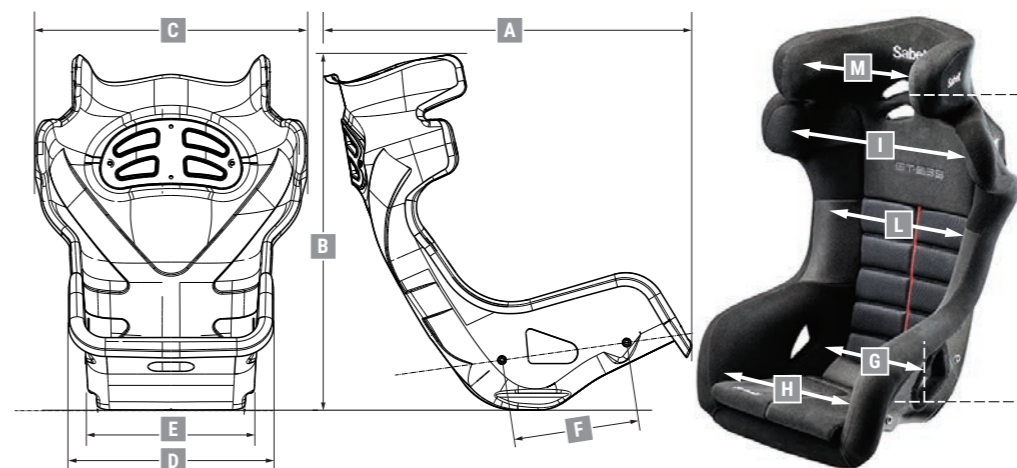

	GT-635 M	GT-635 L	GT-635 XL
SHELL DIMENSIONS (mm)			
A	530	540	
B	910	930	
C	656	676	
D	472	502	
E	400	430	
F	290	290	
G	8,4		11,3
INTERNAL SEAT DIMENSIONS (mm)			
G	316	337	357
H	349	364	384
I	541	546	566
L	368	417	437
M	317	325	325
N	670	656	656
	10,9	13,8	13,5

ACCESSORI E RICAMBI - SPARES AND ACCESSORIES



STAFFE DI DISSAGGIO - FIXING FRAMES



GT-625

NEW



SIZE	L
CODE	RFSEGT621MN



HOMOLOGATION **FIA 8862-2009**

Il sedile GT-625 è stato sviluppato per uso specifico in pista. Un approfondito studio di ergonomia e numerosi test in vettura condotti con piloti professionisti, hanno permesso di sviluppare delle forme confortevoli e al tempo stesso contenitive.

The GT-625 has been developed for the specific use on the track. Comfort and safety are made by an important study of ergonomics and many in car tests with professional drivers.

Dispositivo contenimento testa
Head protection

Tessuto fireproof
Fireproof fabric

Imbottitura alta densità
High density foam

Scocca in carbonio
Carbon shell

Fissaggi laterali
Side fixings
320 mm

Poggiagambe ribassato e sdoppiato
Separate leg cushion



i PER MAGGIORI INFORMAZIONI E CODICI VEDERE PAG. 42-43
FOR FURTHER INFORMATION AND CODES SEE PAGES 42-43

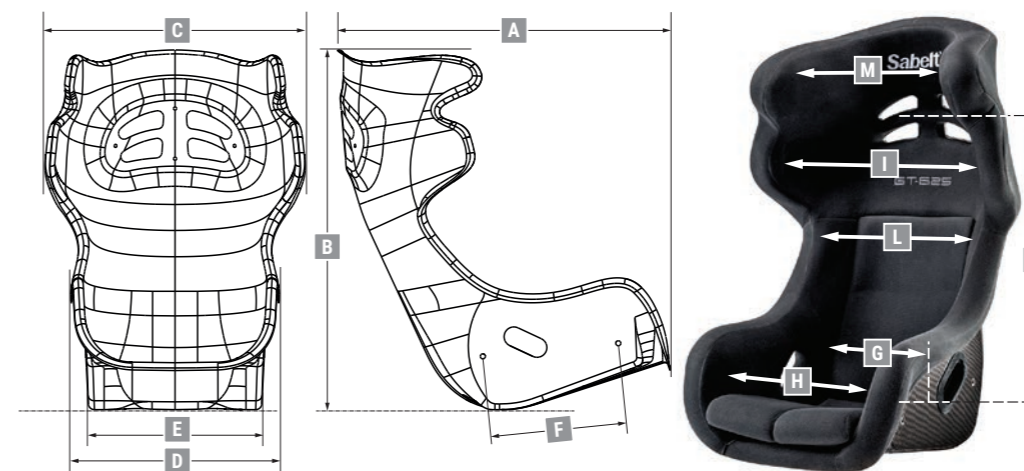

GT-625	
SHELL DIMENSIONS (mm)	
A	580
B	890
C	595
D	540
E	418
F	320
	12,6
INTERNAL SEAT DIMENSIONS (mm)	
G	340
H	370
I	495
L	330
M	370
N	700
	15,0

ACCESSORI E RICAMBI - SPARES AND ACCESSORIES



KIT KF



STAFFE DI DISSAGGIO - FIXING FRAMES



F7

GT-621

NEW



SIZE	M (GT-621 M)	L (GT-621 L)
CODE	RFSEGT621MN	RFSEGT621LN



HOMOLOGATION **FIA 8862-2009**

La scocca è stata realizzata utilizzando carbonio ad alto modulo questo ci ha permesso di ottenere un peso di 8,5 Kg. Il peso totale (che include "impact absorber", schiume, piastrelle di fissaggio e cover) è al di sotto dei 10 Kg, e pone il modello ai vertici della categoria.

The shell is made using high resistance carbon which allowed a seat weight of 8,5 kg. The final weight (including "impact absorber", foams, fixing plates and cover) of less than 10 kg, which puts this model at the top of the range.

Dispositivo contenimento testa
Head protection

Tessuto fireproof
Fireproof fabric

Imbottitura alta densità
High density foam

Scocca in carbonio
Carbon shell

Poggiatesta alto
Single tall leg cushion

Fissaggi laterali
Side fixings
320 mm

i PER MAGGIORI INFORMAZIONI E CODICI VEDERE PAG. 42-43
FOR FURTHER INFORMATION AND CODES SEE PAGES 42-43

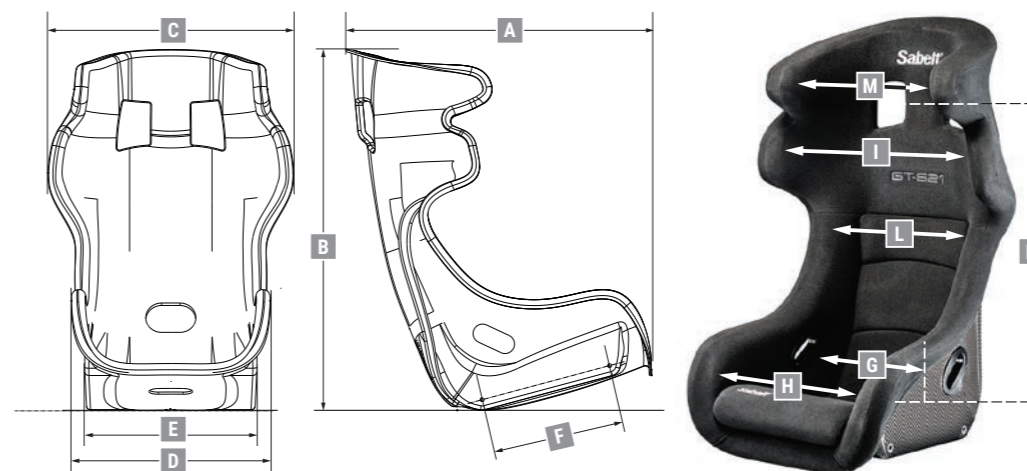

	GT-621 M	GT-621 L
SHELL DIMENSIONS (mm)		
A	567	
B	930	
C	611	
D	497	
E	409	
F	320	
	8,5	
INTERNAL SEAT DIMENSIONS (mm)		
G	331	361
H	348	378
I	495	525
L	335	365
M	350	350
N	642	642
	11,5	11,0

ACCESSORI E RICAMBI - SPARES AND ACCESSORIES



KIT KF



STAFFE DI DISSAGGIO - FIXING FRAMES



F6

TITAN CARBON

NEW



SIZE	L (TITAN CARBON)	XL (TITAN CARBON MAX)
CODE	RFSETITANCARBONLN	RFSETITANCARBONXLN

HOMOLOGATION **FIA 8862-2009**

Scocca in fibra di carbonio lavorata in autoclave, tessuto antiscivolo sulle spalle e innovativo materiale traspirante impiegato su schienalino e seduta, rendono questo sedile uno dei più leggeri, confortevoli e personalizzabili sul mercato.

Autoclave carbon fiber shell. Thanks to anti-slip fabric on shoulder and innovative breathable fabric on backrest and bottom TITAN MAX CARBON is one of the most light and comfortable seat on market.



Poggiagambe sdoppiato
spessore 40 mm
Separate leg cushion
thickness 40 mm

i PER MAGGIORI INFORMAZIONI E CODICI VEDERE PAG. 42-43
FOR FURTHER INFORMATIONS AND CODES SEE PAGES 42-43

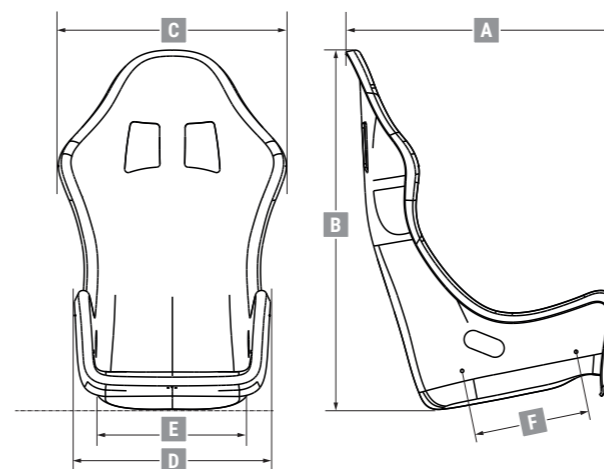

	TITAN CARBON	TITAN CARBON MAX
SHELL DIMENSIONS (mm)		
A	559	
B	935	
C	603	
D	525	
E	418	
F	290	
	4,9	
INTERNAL SEAT DIMENSIONS (mm)		
G	316	341
H	383	403
I	502	530
L	383	400
M	-	-
N	657	657
	7,1	6,9

ACCESSORI E RICAMBI - SPARES AND ACCESSORIES



STAFFE DI DISSAGGIO - FIXING FRAMES

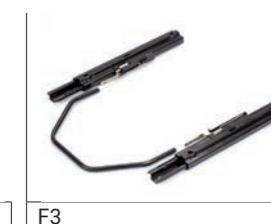

TITAN

NEW



SIZE	L (TITAN)	XL (TITAN MAX)
CODE	RFSETITANLN	RFSETITANXLN



HOMOLOGATION FIA 8855-2009

Con il nuovo TITAN è stato introdotto un design a forme arrotondate che enfatizza la linearità e la leggerezza. Questo design assolutamente unico rende il TITAN un sedile molto più elegante, e immediatamente riconoscibile, elevandolo ad un livello superiore. Sviluppato con le più prestigiose case automobilistiche impegnate nei campionati GT.

- Fissaggio laterale
- Compatibile con cinture a 6 punti grazie a 5° foro passa-cosciale
- Tessuto velluto di alta resistenza all'usura
- Tessuto traspirante sullo schienalino e sulla seduta
- Tessuto antiscivolo sulle spalle

Traditionally the seat design was simple and elegant, the new TITAN introduce a rounded design which underline the lightness of the racing seat. Developed with the best company working in GT championships.

- Lateral fixing
- Suitable to six-point harnesses thanks to crotch straps hole in shell bottom
- High wear resistance vep fabric
- Breathable mesh 3d fabric on backrest and bottom
- Anti-slip kinder point fabric on shoulders

Tessuto antiscivolo
Kinderpoint
Kinderpoint anti-slip
fabric

Imbottitura
alta densità
High density
foam

Tessuto traspirante
Breathable fabric

Scocca
finitura Gel Coat
Gel Coated
shell

Fissaggi laterali
Side fixings
290 mm

Cuscino seduta
spessore 20 mm
Lower cushion
thickness 20 mm

Poggiagambe sdoppiato
spessore 40 mm
Separate leg cushion
thickness 40 mm

Velluto
Vep fabric

Fianchi alti
Tall leg support

PER MAGGIORI INFORMAZIONI E CODICI VEDERE PAG. 42-43
FOR FURTHER INFORMATION AND CODES SEE PAGES 42-43

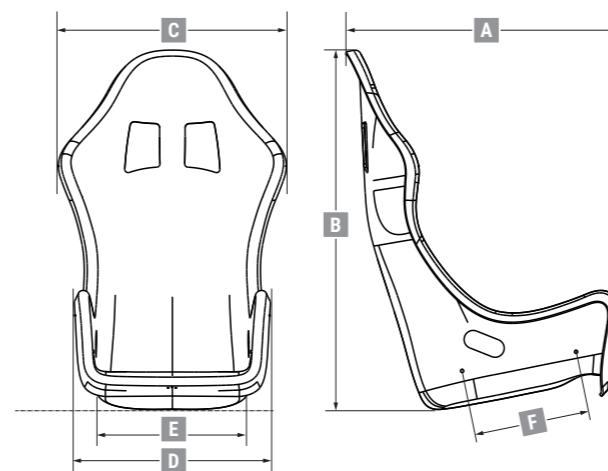

	TITAN	TITAN MAX
SHELL DIMENSIONS (mm)		
A	600	602
B	945	957
C	584	606
D	487	506
E	392	415
F	290	290
📏	7,4	7,8
INTERNAL SEAT DIMENSIONS (mm)		
G	293	313
H	357	367
I	504	517
L	343	379
M	-	-
N	654	690
📏	9,5	9,9

ACCESSORI E RICAMBI - SPARES AND ACCESSORIES



KIT KFP



KIT KP



STAFFE DI DISSAGGIO - FIXING FRAMES

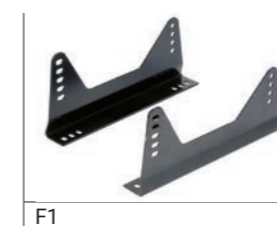

F1

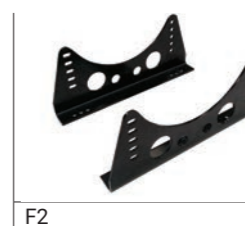

F2



F3

GT-PAD

NEW



SHELL SIZE	XL (GT-PAD)
CODE	RFSEGTPAD *

* Attenzione: questo codice è riferito al sedile esclusi i kit pad. I kit pad sono esclusi e forniti separatamente.
 * Attention: this code refers to the seat excluding the pad kits. The pad kits are provided/supplied separately.



HOMOLOGATION FIA 8855-1999

GT-PAD è il primo sedile componibile Sabelt. Scocca rivestita con velluto ad alta resistenza. I kit pad sono disponibili separatamente. Personalizzabile in base alle differenti taglie di imbottitura e in base al colore.

- Scocca in VTR sviluppata con il know how acquisito nel mondiale GT e WRC.
- Sistema di protezione testa integrato
- Spalle e fianchi disegnati seguendo le prescrizioni del regolamento 8862 per una maggiore sicurezza.
- Nervature di rinforzo posteriori
- Sezioni ergonomiche foam studiate con simulazioni CAD e testate da piloti professionisti per il massimo comfort.
- ADS - Air Ducting System: i pad separati migliorano la circolazione dell'aria aumentando la traspirabilità e migliorando la performance di guida

GT-PAD is Sabelt's first modular seat. The shell is covered by velvet with high resistance. The pad kits are available separately. It is possible to customize the seat according to the different sizes of padding and by color.

- Shell in VTR developed using the know-how acquired thanks to the world's leading experiences GT and WRC.
- Integrated head protection system
- Shoulders and hips designed according to the requirements of Regulation 8862 to improve the driver's safety
- Rear structural reinforcement
- Ergonomic foam sections studied with CAD simulations and tested by our professional drivers to improve driving comfort.
- ADS-Air Ducting System: obtained thanks to the separation of the pad improves air circulation by increasing the seat's breathability and improving driving performance.



Dispositivo contenimento testa
Head protection

Protezione spalle ad alto contenimento.
High containment shoulder protection

Tessuto antiscivolo Kinderpoint
Kinderpoint anti-slip fabric

ADS Air Ducting System

Schienale con curva ergonomica.
Backrest with ergonomic curver.

Fianchi alti
Tall leg support

Cuscino sagomato con sistema anti-submarine integrato.
Shaped pillow with integrated anti-submarine system.

Foro passacintura maggiorato.
Hole of bezel increased

Cuscino seduta spessore 20 mm con tessuto traspirante.
Lower cushion thickness 20 mm with breathable fabric.

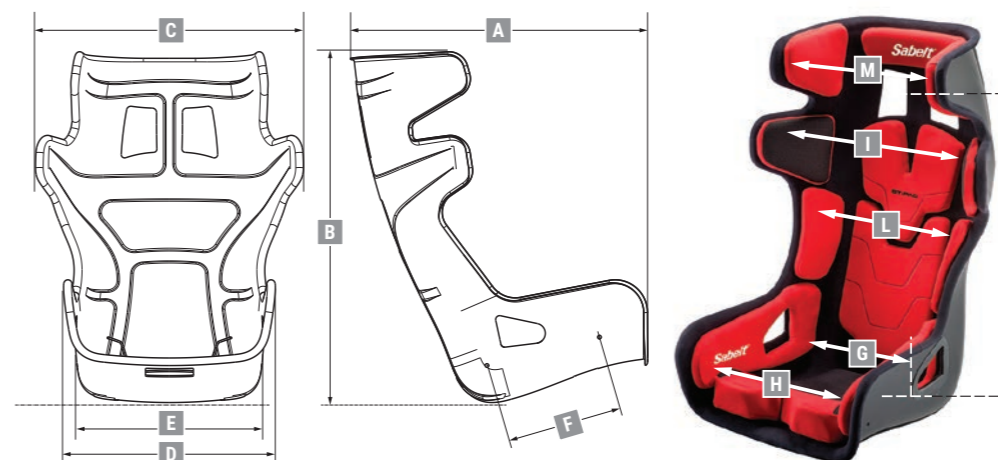

	GT-PAD M	GT-PAD L	GT-PAD XL
SHELL DIMENSIONS (mm)			
A	744		
B	878		
C	670		
D	529		
E	471		
F	290		
INTERNAL SEAT DIMENSIONS (mm)			
G	365	380	395
H	405	420	435
I	540	550	560
L	346	356	366
M	380	380	380
N	660	660	660

PAD KIT

Il kit comprende tutti i cuscini visibili in figura
The kit includes all the pillows visible in the picture



COLOUR	SIZE	CODE
Black	M	RCGTPADKITMN
	L	RCGTPADKITLN
	XL	RCGTPADKITXLN



COLOUR	SIZE	CODE
Red	M	RCGTPADKITMR
	L	RCGTPADKITLR
	XL	RCGTPADKITXLR

ON DEMAND



I kit pad sono disponibili su richiesta con grafica personalizzata e spessore foam su misura.
The pad kits are available upon request with customized graphics and foam thickness

ACCESSORIES



RRGTPAD028

Cuscino seduta spessore 40 mm
Lower cushion thickness 40 mm

STAFFE DI DISSAGGIO - FIXING FRAMES



F1



F2



F3

TAURUS

NEW



SIZE	M (TAURUS M)	L (TAURUS)	XL (TAURUS MAX)
CODE	RFSETAURUSMN	RFSETAURUSN	RFSETAURUSXLN



HOMOLOGATION **FIA 8855-2009**

Con il nuovo TAURUS è stato introdotto un design a forme arrotondate che enfatizza la linearità e la leggerezza. Questo design assolutamente unico rende il TAURUS un sedile molto più elegante, e immediatamente riconoscibile, elevandolo ad un livello superiore. Sviluppato con le più prestigiose case automobilistiche impegnate nel WRC.

- Fissaggio laterale
- Compatibile con cinture a 6 punti grazie a 5° foro passa-cosciale
- Tessuto velluto di alta resistenza all'usura
- Tessuto traspirante sullo schienalino e sulla seduta
- Tessuto antiscivolo sulle spalle

Traditionally the seat design was simple and elegant, the new TAURUS introduce a rounded design which underline the lightness of the racing seat. Developed with the best company working in WRC.

- Lateral fixing
- Suitable to six-point harnesses thanks to crotch straps hole in shell bottom
- High wear resistance vep fabric
- Breathable mesh 3d fabric on backrest and bottom
- Anti-slip kinder point fabric on shoulders



Dispositivo contenimento testa
Head protection

Imbottitura alta densità
High density foam

Tessuto traspirante
Breathable fabric

Scocca finitura Gel Coat
Gel Coated shell

Fissaggi laterali
Side fixings
290 mm

Cuscino seduta spessore 20 mm
Lower cushion
thickness 20 mm

Tessuto antiscivolo Kinderpoint
Kinderpoint anti-slip fabric

Velluto Vep fabric

Fianchi alti
Tall leg support

Poggiatesta sdoppiato spessore 40 mm
Separate leg cushion
thickness 40 mm

PER MAGGIORI INFORMAZIONI E CODICI VEDERE PAG. 42-43
FOR FURTHER INFORMATIONS AND CODES SEE PAGES 42-43

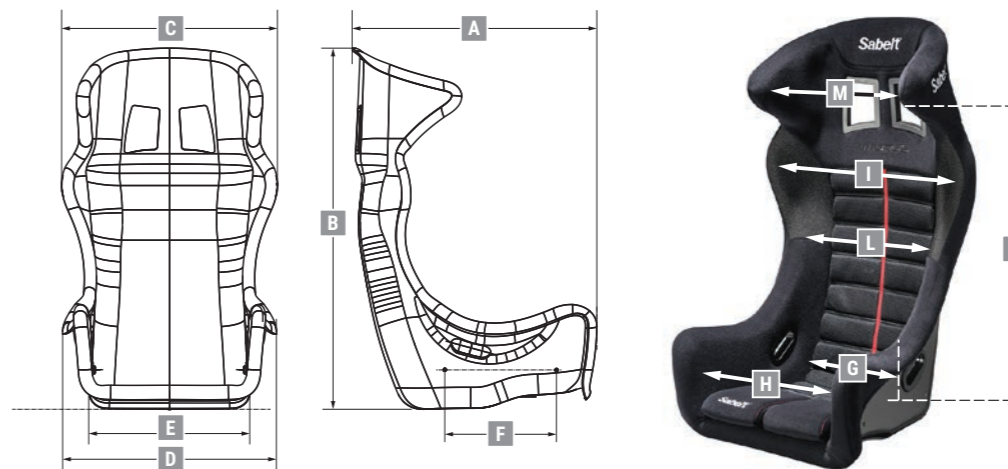

TAURUS M TAURUS TAURUS MAX

SHELL DIMENSIONS (mm)			
A	543	550	586
B	925	979	980
C	579	582	588
D	475	481	519
E	377	392	411
F	290	290	290
⊕	8,4	9,0	9,7

INTERNAL SEAT DIMENSIONS (mm)			
G	300	318	326
H	364	348	393
I	486	501	512
L	345	362	393
M	341	357	394
N	685	717	716
⊕	10,5	11,2	11,4

ACCESSORI E RICAMBI - SPARES AND ACCESSORIES



STAFFE DI DISSAGGIO - FIXING FRAMES



GT-3

NEW



SIZE	L
CODE	RFSEGT3N



HOMOLOGATION **FIA 8855-2009**

Il GT3 è il sedile in fibra di vetro più venduto, progettato con particolare attenzione al comfort, l'innovativa laminazione leggera riduce il peso della scocca del 15%, il nuovo poggia gambe sdoppiato è stato ideato per dare un miglior comfort di guida.

- Fissaggio laterale
- Compatibile con cinture a 6 punti grazie a 5° foro passa-cosciale
- Tessuto velluto di alta resistenza all'usura
- Poggia gambe sdoppiato rimovibile

GT3 is the bestselling fiber-glass seat, it was designed with a specific care to comfort. The shell weight 15% less thanks to the innovative and lightweight lamination. The new separate leg cushion has been developed to give a better ride comfort.

- Lateral fixing
- Suitable to six-point harnesses thanks to crotch straps hole in shell bottom
- High wear resistance vep fabric
- Separate and removable leg cushion



PER MAGGIORI INFORMAZIONI E CODICI VEDERE PAG. 42-43
FOR FURTHER INFORMATION AND CODES SEE PAGES 42-43

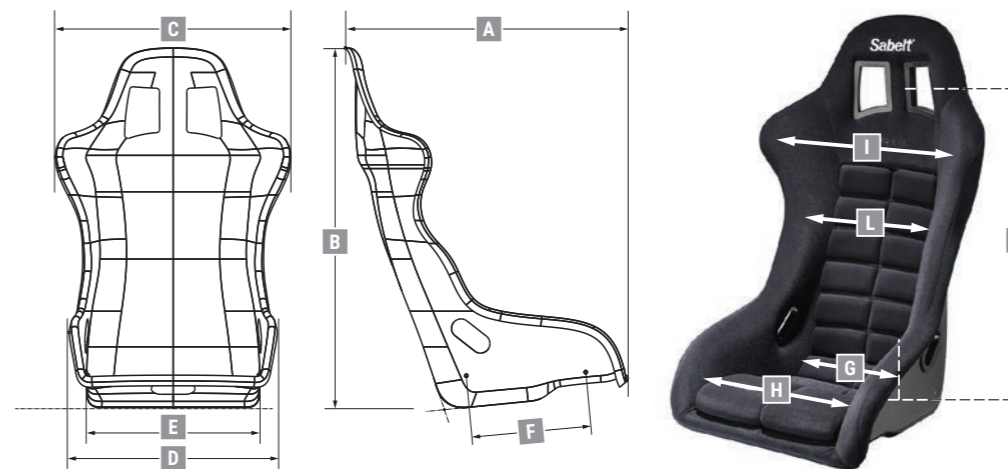

GT-3	
SHELL DIMENSIONS (mm)	
A	460
B	920
C	592
D	539
E	416
F	290
🔒	7,2
INTERNAL SEAT DIMENSIONS (mm)	
G	355
H	386
I	469
L	354
M	
N	706
🔒	9,8

ACCESSORI E RICAMBI - SPARES AND ACCESSORIES



KIT KP



KIT KP

STAFFE DI DISSAGGIO - FIXING FRAMES



F1

F2

F3

RACER DUO

NEW



SIZE	L
CODE	RFSERACERDUON



HOMOLOGATION **FIA 8855-2009**

RACER DUO ha una struttura tubolare in acciaio, la sua forma ergonomica garantisce un ottimo contenimento laterale, il nuovo poggia gambe sdoppiato è stato ideato per dare un miglior comfort di guida, i nuovi ricami garantiscono un design accattivante.

- Doppi attacchi laterali e inferiori
- Compatibile con cinture a 6 punti grazie al 5° foro passa-cosciale
- Tessuto velluto ad alta resistenza all'usura
- Poggia gambe sdoppiato rimovibile

RACER DUO has a tubular steel frame structure. Its ergonomic shape ensures an excellent lateral support. The new separate leg cushion has been developed to give a better drive comfort. The new embroideries guarantee an aggressive design.

- Double lateral and lower fixing
- Suitable to six-point harnesses thanks to crotch straps hole in shell bottom
- High wear resistance vep fabric
- Separate and removable leg cushion

Velluto alta resistenza
Vep fabric

Fianchi bassi
Thin leg support

Poggiagambe sdoppiato
spessore 40 mm
Separate leg cushion
thickness 40 mm

N°4 Fissaggi inferiori
N°4 Bottom fixings
270 x 345 mm

Fissaggi laterali
Side fixings
290 mm

i PER MAGGIORI INFORMAZIONI E CODICI VEDERE PAG. 42-43
FOR FURTHER INFORMATIONS AND CODES SEE PAGES 42-43

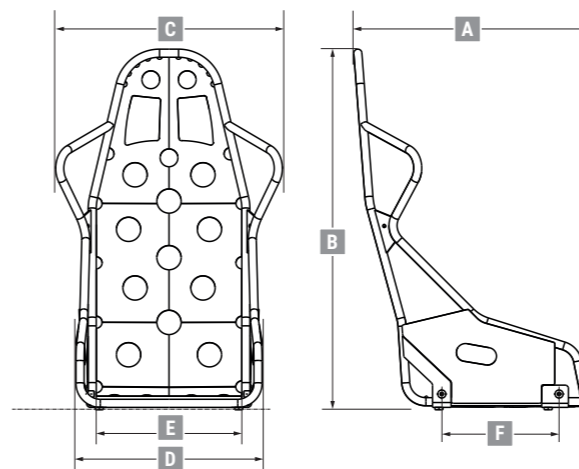

RACER DUO	
SHELL DIMENSIONS (mm)	
A	463
B	890
C	582
D	489
E	422
F	290
🔒	10,0
INTERNAL SEAT DIMENSIONS (mm)	
G	324
H	377
I	509
L	374
M	
N	637
🔒	12,0

ACCESSORI E RICAMBI - SPARES AND ACCESSORIES



KIT KP



KIT KP

STAFFE DI DISSAGGIO - FIXING FRAMES



F1



F2



F3

TRUE SUITS



MADE TO MEASURE TEMPLATE - ISTRUCTIONS

- 1** Larghezza spalle (da una testa dell'omero all'altra aderendo alla schiena)
Shoulder breadth (from points of shoulders bones across back)
- 2** Lunghezza busto anteriore (dalla base del laterale del collo alla vita)
Body lenght from inside shoulder to waist
- 3** Circonferenza torace
Chest circumference
- 4** Circonferenza vita
Waist circumference
- 5** Circonferenza bacino (all'altezza dei glutei nel punto più largo)
Hip circumference
- 6** Circonferenza coscia
Thigh circumference
- 7** Circonferenza polpaccio
Calf circumference
- 8** Lunghezza gamba (dalla vita al malleolo)
Outside leg length from waist to malleolus
- 9** Lunghezza entrogamba desiderata (dal cavallo alla caviglia)
Desired lenght from the crotch to ankle
- 10** Circonferenza bicipite
Biceps circumference
- 11** Lunghezza manica (dalla testa dell'omero al polso con braccio piegato)
Sleeve lenght from point of shoulder bone to wrist (armi bent)
- 12** Lunghezza cavallo totale (dalla base anteriore al collo)
Crotch length from front collar bone through top of inside leg to back neck
- 13** Circonferenza vita nel punto più esteso
Maximum waist circumference
- 14** Lunghezza busto posteriore (dalla base posteriore del collo alla vita)
Lenght from neck to waist

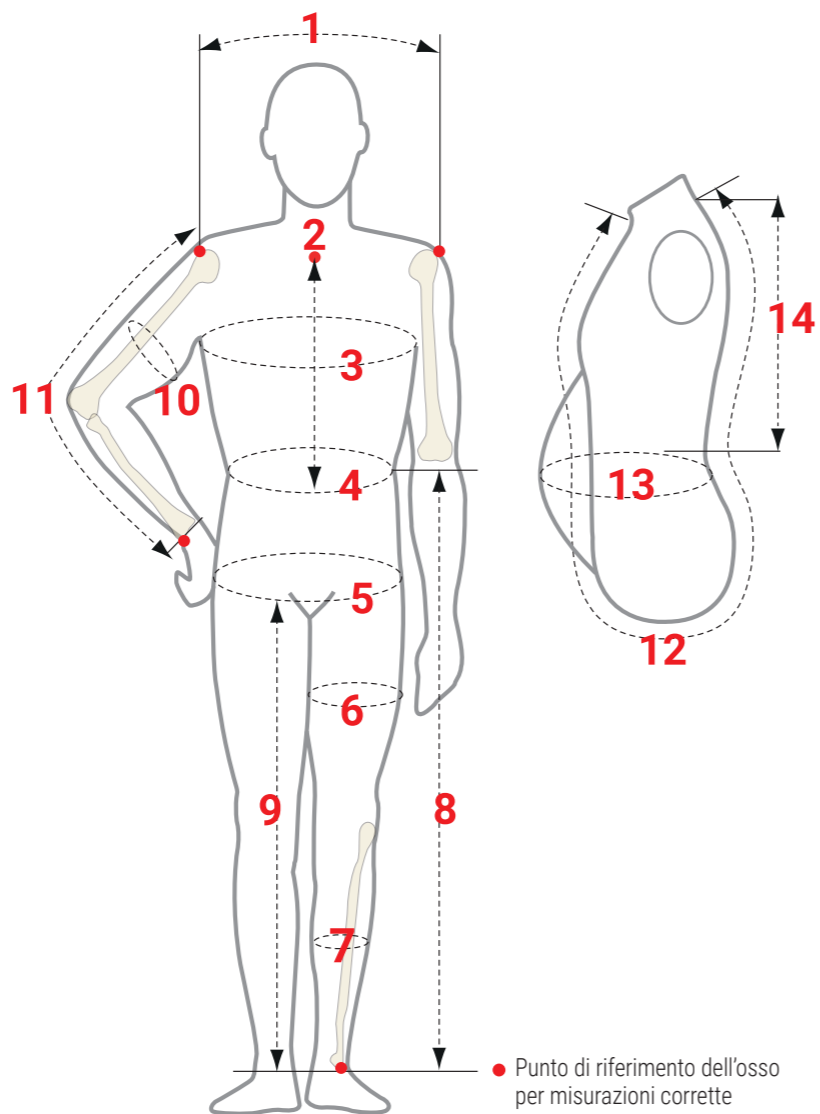

● Punto di riferimento dell'osso per misurazioni corrette

Bone's landmark for correct measurements

MADE TO MEASURE TEMPLATE - SHEET

Ricamo sulla cintura - Embroidery on belt: SI NO

Colore filo - Thread colour:

Nome - Name:

Gruppo sanguigno - Blood group:

Bandiera - Flag:

Nome pilota - Driver's name:

Height (inch.)

Statura (cm)

Weight (lbs)

Peso (kg)

Vestibilità desiderata: attillata morbida

Desired fitting: close fitting loose fitting

MEASURE BOARD - SCHEDA MISURE

1				8			
2				9			
3				10			
4				11			
5				12			
6				13			
7				14			

NOTES - NOTE



TABELLA MISURE STANDARD - STANDARD SIZE CHART

TAGLIA SIZES	TORACE CHEST	VITA WAIST	BACINO HIPS	PESO WEIGHT	ALTEZZA HEIGHT
44	82-86	69-73	81-85	43-48	162-165
46	86-90	73-77	85-89	49-54	164-166
48	90-94	77-81	89-93	55-60	167-169
50	94-98	81-85	93-97	61-66	170-172
52	98-102	85-89	97-101	67-72	173-175
54	102-106	89-93	101-105	73-78	176-179
56	106-110	93-97	105-109	79-84	180-184
58	110-114	97-101	109-113	85-90	185-187
60	114-118	101-105	113-117	91-96	188-190
62	118-122	105-109	117-121	97-102	191-193
64	122-126	109-113	121-125	103-108	194-196
66	126-130	113-117	125-129	109-114	197-199

Le misure sono espresse in cm e si riferiscono al corpo e non alla tuta.
Sizes listed are in cm and are for body measurements, not of the suit.

HERO TS-9

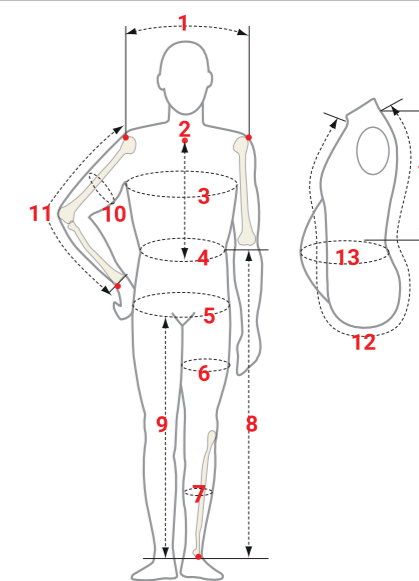
STRATO ESTERNO
EXTERNAL LAYER

S-DRY

Tessuto esterno: tela anti peeling S-Dry superleggero ad alta traspirabilità.
External layer: anti pilling plain weave S-Dry superlight and extremely breathable.

STRATI INTERNI
INTERNAL LAYERS

Strato intermedio in nido d'ape e strato interno in magliana.
Honeycomb intermediate layer and knitted inner layer.

PESO SANDWICH
SANDWICH WEIGHT295 g/m²OMOLOGAZIONE
HOMOLOGATION

FIA 8856-2000

TAGLIE
SIZES

46 - 66



- FIA8856-2000
- Peso sandwich 295 g/m²
- Tessuto esterno anti peeling S-Dry superleggero ad alta traspirabilità
- Design semplice e leggero
- Vestibilità slim
- Punto vita ribassato
- Inserti stampati
- Collo ribassato
- Interno tuta senza impuntura
- Manica preformata
- Nuovo materiale elastico per zona lombare
- Taglie 46 - 66

- FIA8856-2000
- Fabric weight 295 g/m²
- Anti-bobbling external layer S-Dry lightweight and extremely breathable
- Simple and lightweight pattern
- Slim fit
- Lower crotch-belt area
- Printed inserts
- Lower neck
- Seamless internal
- Pre-formed arms
- New elastic material lombar area
- Sizes 46 - 66



RFTITS9RS..

RFTITS9NR..

RFTITS9BI..

RFTITS9BR..

NEW



DIAMOND TS-7



STRATO ESTERNO
EXTERNAL LAYER

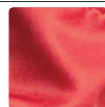

Tessuto esterno in Diamond
External layer in Diamond



STRATI INTERNI
INTERNAL LAYERS

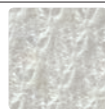

Strato intermedio in nido d'ape e strato
interno in maglina.
Honeycomb intermediate layer and knitted
inner layer.



PESO SANDWICH
SANDWICH WEIGHT

360 g/m²

OMOLOGAZIONE
HOMOLOGATION

FIA 8856-2000

TAGLIE
SIZES

46 - 66



- FIA8856-2000
- Peso sandwich 360 g/m²
- Tessuto esterno DIAMOND
- Design bicolore con inserti in tessuto
- Vestibilità slim
- Punto vita ribassato
- Collo ribassato
- Interno tuta senza impuntura
- Manica preformata
- Nuovo materiale elastico per zona lombare
- Taglie 46 - 66

- FIA8856-2000
- Fabric weight 360 g/m²
- Anti-bobbling external layer DIAMOND
- Bi-color pattern with inserts made of fabric
- Slim fit
- Lower crotch-belt area
- Lower neck
- Seamless internal
- Pre-formed arms
- New elastic material lombar area
- Size 46 - 66



RFTITS7RS..

RFTITS7BI..

RFTITS7BR..

RFTITS7VA..

RFTITS7GR..

RFTITS7NR..



CHALLENGE TS-3



STRATO ESTERNO
EXTERNAL LAYER

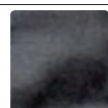

Tessuto esterno in fibra aramidica tipo spina
External layer in aramid fiber



STRATI INTERNI
INTERNAL LAYERS

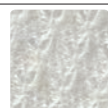

Doppio strato in jersey aramidico.
Double layers in aramidic jersey.

PESO SANDWICH
SANDWICH WEIGHT

380 g/m²

OMOLOGAZIONE
HOMOLOGATION

FIA 8856-2000

TAGLIE
SIZES

46 - 66



- FIA8856-2000
- Peso sandwich 380 g/m²
- Tessuto esterno soffice tessuto Ignifugo NOMEX spina
- Design bicolore
- Vestibilità slim
- Collo ribassato
- Punto vita ribassato
- Nuovo pannello elastico per zona lombare
- Taglia 46 - 66

- FIA8856-2000
- Fabric weight 380 g/m²
- Anti-bobbling external layer soft NOMEX fireproof fabric
- Bi-color pattern
- Slim fit
- Lower neck
- Lower crotch-belt area
- New elastic panel for lombar area
- Size 46 - 66



RFTITS3BR..

NEW

RFTITS3NG..

NEW



RFTITS3NR..

RFTITS3RS..

RFTITS3BL..

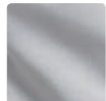

TI-090

STRATO ESTERNO EXTERNAL LAYER	
Tessuto esterno in fibra aramidica tipo twill. External layer in twill aramidic fiber.	
STRATI INTERNI INTERNAL LAYERS	
Strato intermedio in fibra aramidica e strato interno in tessuto aramidico-viscosa. Intermediate layer in aramidic fabric and inner layer in aramidic-viscose fabric.	
PESO SANDWICH SANDWICH WEIGHT	395 g/m ²
OMOLOGAZIONE HOMOLOGATION	FIA 8856-2000
TAGLIE SIZES	S - XXL

- Tuta entry level monocolore
- Peso sandwich 395 g/m²
- Tessuto esterno anti peeling
- Design semplice e lineare

- Monochrome entry level suit
- Sandwich weight 395 g/m²
- Anti-bobbling external layer
- Simple and linear design



RFTI090NR..

NEW





Solo i migliori diventano Abarth

Scegliamo i nostri partner con la stessa attenzione con cui curiamo l'elaborazione di ogni singola Abarth. Per questo entrano nelle nostre "officine" solo i brand con cui condividiamo valori, passione per la competizione e determinazione nel superarsi in ogni sfida quotidiana.

Only the best become Abarth

We choose our partners with the same care that we use to tune every single Abarth. That's why only brands who share our values, passion for competition and determination to outdo themselves in every daily challenge enter our "workshops".



FIA 8856-2000 SIZE: 46-66 RFTITS3RSAB..



FIA 8856-2000 SIZE: S-XL Z150UI100TOPAB



FIA 8856-2000 SIZE: 8-12 RFTG03RSAB..



FIA 8856-2000 SIZE: 36-47 RFTB03RSAB..



UNDERWEAR

UI-500

NEW

**UNDERWEAR STRETCH FIT SENZA CUCITURE**

La composizione di questa nuova linea underwear rende i capi leggeri, resistenti all'usura e molto confortevoli. L'utilizzo della fibra Lenzing FR, che è composta da materiali grezzi naturali, e che mantiene il corpo asciutto e fresco, unita al modacrilico e all'elastane, che rendono i capi totalmente stretch, fanno di questa linea la più comoda e la più innovativa di tutta la gamma. Il tessuto indemagliabile bielastico e senza cuciture ha un'alta resistenza all'usura ed è molto leggero.

STRETCH FIT SEAMLESS UNDERWEAR

The composition of this new underwear line makes the clothing light, resistant and very comfortable. The use of Lenzing FR fiber, which is made of a natural raw material, and keeps the body dry and cool, together with the modacrylic and elastane, which make the garments totally stretch, make this line the most convenient and the most innovative across the range. The two way stretch warp knit seamless fabric has a high wear resistance and is very light.

**SOTTOCASCO APERTO
OPEN FACE BALACLAVA**

FIA 8856-2000

 WHITE Z150UI500BALB

TAGLIA UNICA - ONE SIZE

**LUPETTO MANICA LUNGA
LONG SLEEVED ROLL NECK TOP**

FIA 8856-2000

 WHITE Z150UI500TOPB

XS - S / M - L / XL - XXL

**PANTALONI
TROUSERS**

FIA 8856-2000

 WHITE Z150UI500PANTB

XS - S / M - L / XL - XXL

UI-100

NEW

**SOTTOCASCO APERTO**

In maglia 50% Nomex e 50% viscosa.

OPEN FACE BALACLAVA

New underwear 50% Nomex and 50% viscose.

FIA 8856-2000

 WHITE Z150UI100BALB

 BLACK Z150UI100BALN

TAGLIA UNICA - ONE SIZE

LUPETTO MANICA LUNGA

Realizzata in maglia 50% Nomex e 50% viscosa. Nuovo disegno raglan per il top della manica che aumenta il comfort.

LONG SLEEVED ROLL NECK TOP

50% Nomex and 50% viscose. New raglan design for the top sleeve for maximum comfort.

FIA 8856-2000

 WHITE Z150UI100TOPB

 BLACK Z150UI100TOPN

S - M - L - XL

PANTALONI

In maglia 50% Nomex e 50% viscosa.

TROUSERS

50% Nomex and 50% viscose.

FIA 8856-2000

 WHITE Z150UI100PANTB

 BLACK Z150UI100PANTN

S - M - L - XL

**CALZE LUNGHE
LONG SOCKS**

FIA 8856-2000

 WHITE Z150UI100SOCKSB..

 BLACK Z150UI100SOCKSBN..

S - M - L - XL



SCARPE SHOES

PININFARINA PF-1

NEW

Nuova scarpa nata dalla collaborazione tra Sabelt e Pininfarina. L'unione di due eccellenze italiane per realizzare un prodotto esclusivo ed iconico. Questo modello è caratterizzato dalla grande esperienza Racing di Sabelt e da un Design unico e curato che distingue lo stile Pininfarina.

New shoe born from the collaboration between Sabelt and Pininfarina. The union of two italian excellences to create an exclusive and iconic product. This model is characterized by Sabelt's Racing experience and by a unique and cool design which distinguishes Pininfarina's style.

HOMOLOGATION	N/A
TAGLIE - SIZES	36 - 48
CODE	RFTBR4PIN..



- Pelle ultra sottile - *Ultra thin calf leather*
- Cinturino di sicurezza - *Safety strap*
- Protezione malleolo con pad - *Ankle protection with padding*
- Protezione laterale bombata - *Embossed lateral protection*
- Rinforzo esterno in pelle tipo Gum - *Gum leather external reinforcement*
- Insetto posteriore flessibile con area riflettente - *Flexible insert with reflective area*

- Tessuto interno traspirante in mesh 3d - *Internal breathable mesh 3d fabric*
- Pelle traforata traspirante - *Breathable perforated leather*
- Soletta interna con gel shock absorber - *Inner sole with gel shock absorber*
- Suola Racing super grip - *Racing super grip sole*

PININFARINA PF-1X

NEW

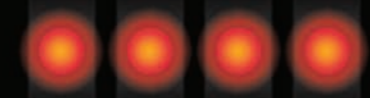

COMING SOON

FIA HOMOLOGATED VERSION

HERO TB-9

- Nuova scarpa superleggera
- Tomaia in morbida pelle liscia traforata
- Nuova suola Sabelt® progettata per migliorare il grip e facilitare il movimento sulla pedaliera grazie al design slim

- *New high level, lightweight shoes*
- *Upper shoes made of soft, perforated leather*
- *New Sabelt® sole designed to improve the grip and facilitate movements across the pedals thanks to the slim design*

HOMOLOGATION	FIA 8856-2000
TAGLIE - SIZES	36 - 48



RFTB09BI..

RFTB09NR..

RFTB09RS..

NEW

RS-402

- Scarpa dal design classico.
- Tomaia scamosciata.
- Suola con design digit.

- *Classic design shoe.*
- *Soft suede for the upper.*
- *"Digit" sole design.*

HOMOLOGATION	FIA 8856-2000
TAGLIE - SIZES	36 - 47



Suola "digit" per un miglior grip.
"Digit" sole for a better grip



RFRS402R..

RFRS402N..

FINO AD ESAURIMENTO - UNTIL STOCK LAST

CHALLENGE TB-3

NEW

- Nuova scarpa Challenge
- Tomaia in pelle scamosciata
- Suola Digit, per conciliare leggerezza e grip, garantendo la miglior performance sui pedali
- Disponibili in diverse varianti cromatiche
- Nuova grafica coordinata

- *New Challenge shoe*
- *Suede vap*
- *Digit sole for weighthness and grip, to ensure the best performance*
- *Available in different colors*
- *New coordinate image*

HOMOLOGATION	FIA 8856-2000
TAGLIE - SIZES	36 - 47



Suola "digit" per un miglior grip.
"Digit" sole for a better grip



RFTB03NRG..

RFTB03BL..

RFTB03RS..

RFTB03NRR..

GUANTI GLOVES



HERO TG-9

- Nuovo guanto alto di gamma
- Palmo in silicone nero con logo Sabelt®
- Interno palmo rinforzato
- Modelliera ridisegnata per migliorare il confort
- Design semplice e lineare, adatto ad essere personalizzato

- New high level fireproof gloves
- Silicon base palm with Sabelt® logo
- Reinforced internal palm
- New fitting - improved confort
- Simple design, easy to be customized

HOMOLOGATION	FIA 8856-2000
TAGLIE - SIZES	8 - 12

TAGLIE GUANTI / GLOVES SIZE

cm	17,5 - 19,5	19,5 - 21,5	21,5 - 23,5	23,5 - 25,5	> 25,5 cm
size	08	09	10	11	12
size	XS	S	M	L	XL

Facendo il pugno, misurare attorno al punto più largo della mano oltre le nocche, escludendo il pollice.
Close your fist, measure around the widest part of your hand, thumb excluded.



Palmo con spalmatura piatta ergonomica ad alto grip per una migliore performance sul volante.

Palm with spreaded flat grip treatment for a better performance on the steering wheel.

Elasticizzazione sul polso.
Elasticated wrist



In compliance with FIA standard 8856-2000
Sabelt®
Year of manufacture 2016



RFTG09GFN..

RFTG09NRN..

RFTG09RSN..

RFTG09BIN..

NEW

NEW

DIAMOND TG-7

NEW

- Nuovo guanto Diamond
- Maggior comfort garantito dalle cuciture esterne
- Palmo con applicazioni in pelle Digit
- Garantisce comfort e aderenza al volante
- Ottima vestibilità grazie all'inserto elastico sul polso
- Nuove grafiche e accostamenti cromatici

- New Diamond glove
- Best comfort thanks to external stitchings
- Guarantees comfort and good performance on the steering wheel
- Perfect fit thanks to elasticated wrist
- New graphic lines and color combinations

HOMOLOGATION	FIA 8856-2000
TAGLIE - SIZES	8 - 12



Elasticizzazione sul polso.
Elasticated wrist



In compliance with FIA standard 8856-2000
Sabelt®
Year of manufacture 2017



RFTG07RS..

RFTG07BL..

RFTG07NR..

CHALLENGE TG-3

NEW

- Nuovo guanto Challenge
- Pelle scamosciata su palmo
- Loghi e grafiche stampate per non interferire con leggerezza e performance
- Cuciture interne

- New Challenge glove
- suede on palm
- Internal stitchings

HOMOLOGATION	FIA 8856-2000
TAGLIE - SIZES	8 - 12



RFTG03RS..

RFTG03BL..

RFTG03NR..

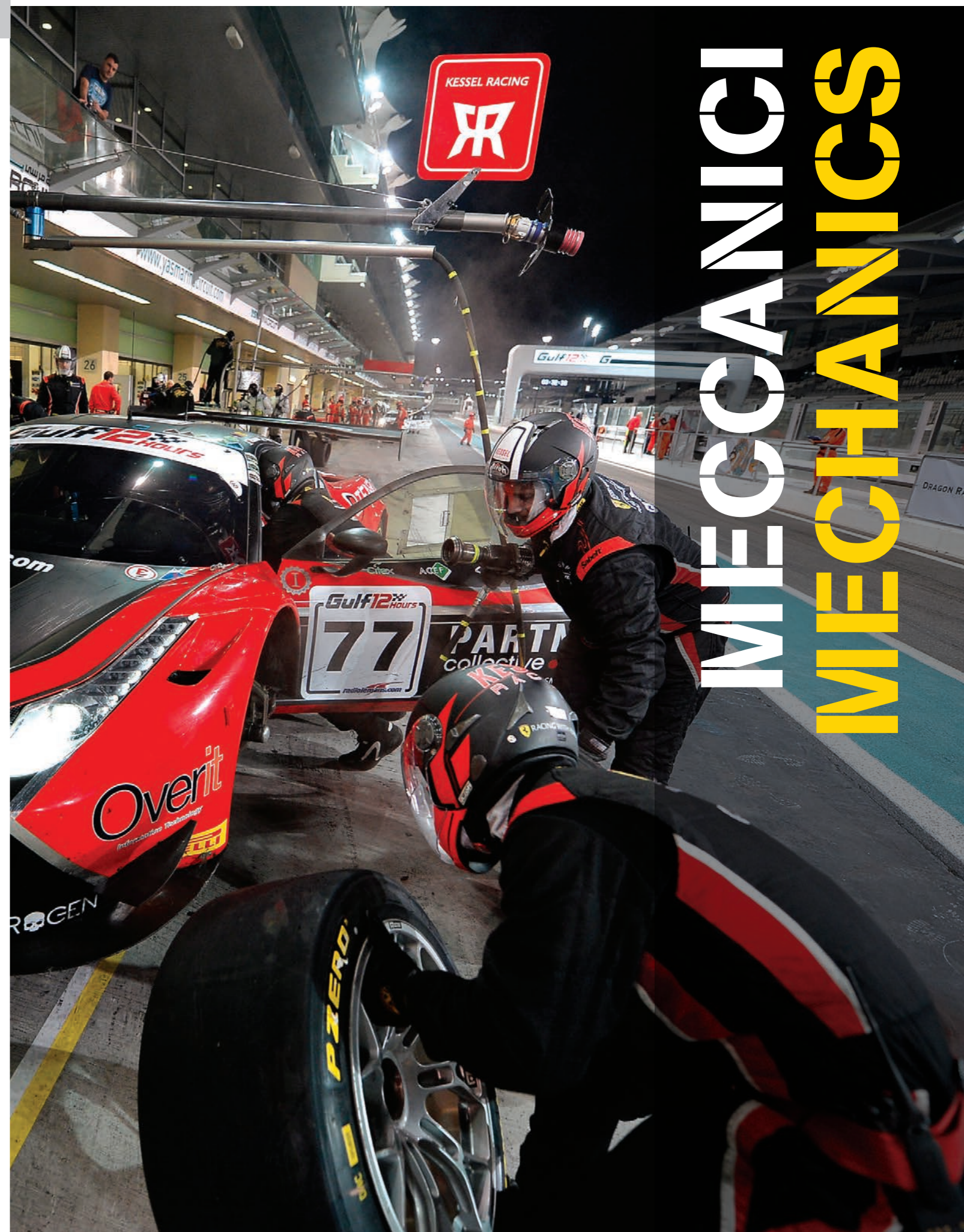

MECHANICS
MECHANICS

TM-100

Tuta meccanico in cotone 100%, disegno TI-520, manica flottante, elastico in vita, doppia tasca applicata.

Mechanis suit made of 100% cotton, TI-520 design, floating sleeves, waist stretch band, two pockets.

TAGLIE - SIZES	46 - 66
----------------	---------



M14360RSC..	M14360ASC..	M14360NSC..
-------------	-------------	-------------

CHALLENGE MB-3

NEW

Nuova scarpa meccanico. Tomaia in pelle scamosciata. Suola alta con nuova geometria antiscivolo per garantire sicurezza e maggior grip. Mescola antistatica, antifiama e resistente agli oli e idrocarburi. Lingua posteriore in pelle morbida liscia per un maggior comfort. Nuova grafica coordinata.

New machanis shoe. Suede vamp. Wide sole, with a new anti-slip geometry to ensure safety and grip. Antistatic, flameproof and antifiammaand oils and hydrocarbons resistant mesh. Soft rear tongue to ensure better comfort. New coordinate image.



RFMB03NR..

HOMOLOGATION	FIA 8856-2000
TAGLIE - SIZES	36 - 46



Suola alta, speciale design, per un grip migliore e per facilitare i piegamenti. Wide sole, with special grip design allowing easy bending.



Guanto e manicotto di protezione contro i rischi meccanici e di calore. Tessuto in cotone e kevlar. Protegge fino a 300° C. In accordo con le direttive Europee: -89/686 (dexterity 4) EN420:2003, -EN388:2003. Resistente al taglio (5/5). Resistente all'abrasione (2/4). Resistente agli strappi (4/4). Resistente alla fiamma (4/4). Resistente al calore (2/4).

Protective gloves and arm protections against mechanical and thermal risks. Cotton and Kevlar fabric. Protects till 300° C. In compliance with European directives: -89/686 (dexterity 4) EN420:2003, -EN388:2003. Cut resistance (5/5). Abrasion resistance (2/4). Tearing resistance (4/4). Flammability resistance (4/4). Heat contact resistance (2/4).

< Z120560	Z120760 >
TAGLIA UNICA - ONE SIZE	

Guanto in maglina di cotone peso medio. Palmo con antiscivolo blu. Colore: Bianco naturale.

Knitted cotton gloves medium weight. Blu rubber peening for better grip on the palm. Colour: natural white.

Z120460
TAGLIA UNICA - ONE SIZE





VOLANTI STEERING WHEELS

SW-733

NEW Volante piatto. Pelle scamosciata nera.
Flat steering wheel. Black suede leather.

RFV02026
ø 330 mm



SW-633

Volante piatto. Pelle scamosciata nera.
Flat steering wheel. Black suede leather.

RFV02010X
ø 330 mm



SW-465

Volante mezzo calice 65 mm. Pelle scamosciata nera.
Half dished steering wheels 65 mm. Black suede leather.

RFV02009X
ø 350 mm



SW-635

Volante piatto. Pelle scamosciata nera.
Flat steering wheel. Black suede leather.

RFV02007X
ø 350 mm



SW-390

Volante a calice - Profondità 90 mm, Pelle scamosciata nera.
Dished steering wheels - 90 mm depth. Black suede leather.

RFV02005X
ø 350 mm



ACCESSORI ACCESSORIES

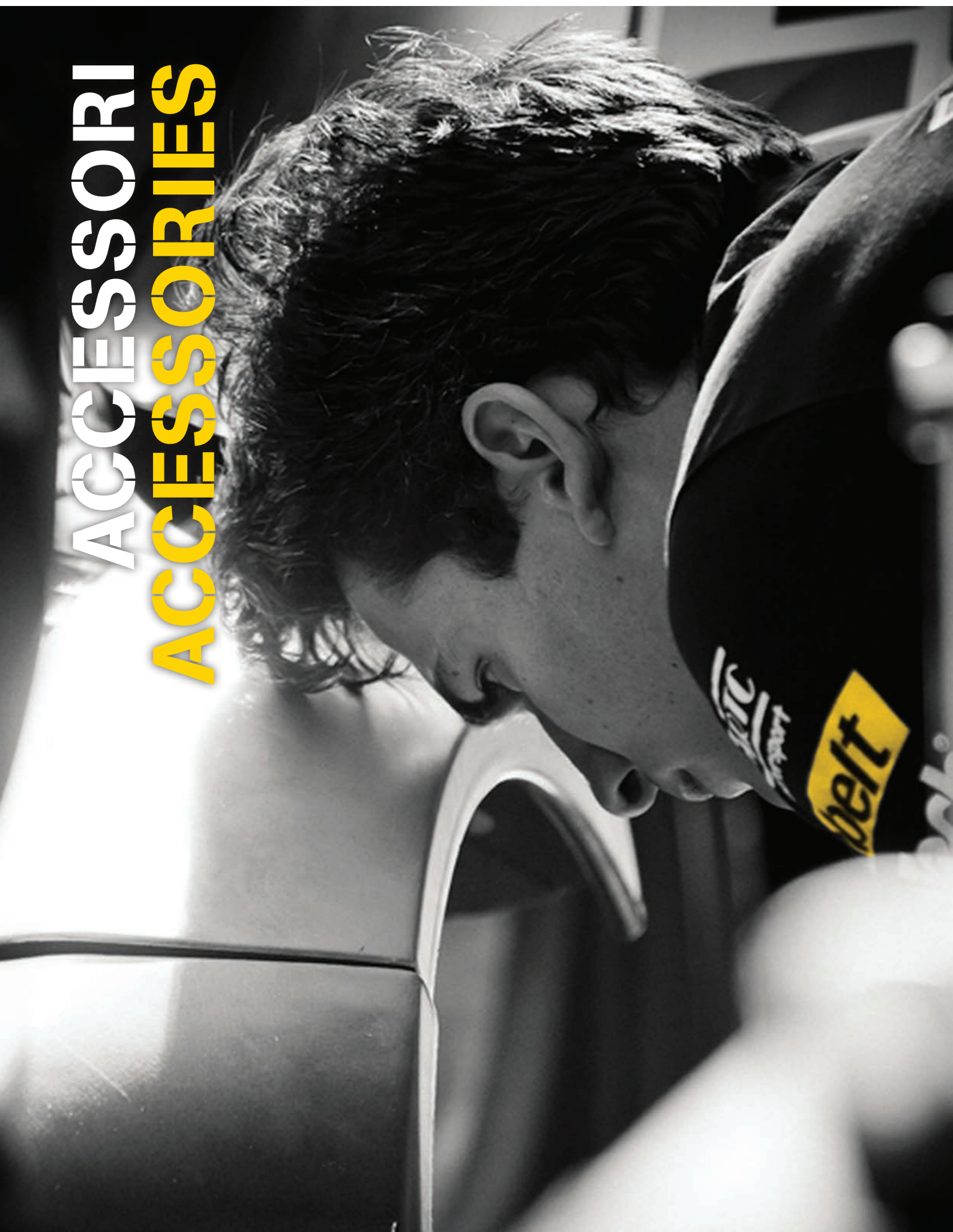

Mozzo volante a sgancio rapido per gruppo N, conforme alle norme FIA, compatibile con tutti i volanti Sabelt a 6 fori.

Quick release steering boss for group N cars, conformity to FIA regulation, compatible with all Sabelt 6-slot steering wheels.

M220SR6GRN



Mozzo volante a sgancio rapido da saldare per vetture Turismo/Rally, conforme alle norme FIA, compatibile con tutti i volanti Sabelt a 6 fori.

Quick release steering boss to be welded for Touring/Rally cars, conformity to FIA regulation, compatible with all Sabelt 6-slot steering wheels.

M220SR6B



CCAC0023

CCAC0027

CCAC0024

CCAC0028

CCAC0026

CCAC0025

GANCIO TRAINO - TOW STRAP

Lunghezza: 260 mm. Diametro foro: 15,5 mm. Length: 260 mm. Hole diameter: 15,5 mm.



MANIGLIA PORTA DOOR STRAP

Maniglia porta da avvitare al pannello porta. Lunghezza: 220 mm. Diametro foro: 9,5 mm.

Door strap to be fixed on the door panel. Length: 220 mm. Hole diameter: 9.5 mm.

CCAC0022

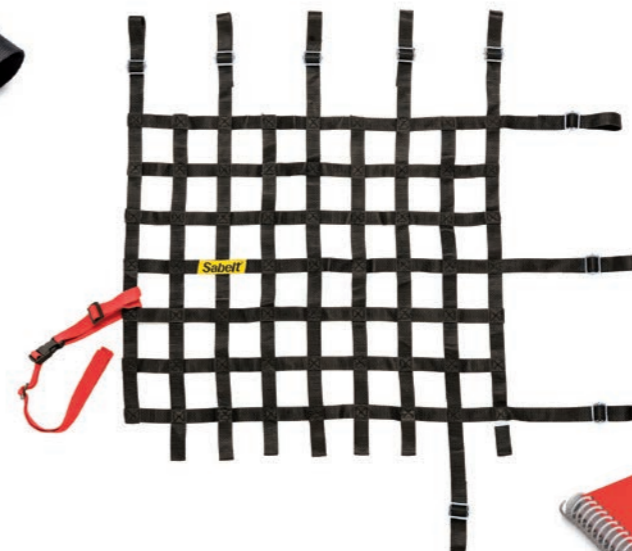

RETE FINESTRINO WINDOW NET

Conforme FIA.
In compliance with FIA regulation.

Z280985



RFTINAVRS

RFTINAVBR

RFTINAVBI

RFTINAVNR



QUADERNO - NOTEBOOK

Misura 22 x 17,5 cm
Size 22 x 17,5 cm

Z240600

TASCA NAVIGATORE CO-DRIVER POCKET

In tessuto Nomex. Chiusura con velcro.
Misura 17 x 23 cm.
Nomex fabric. Velcro locking. Size 17 x 23 cm.

BS-790

930 x 400 x 390

Borsone multi scomparto per un equipaggiamento completo. Vano imbottito (spugna 10 mm) porta casco, scomparto laterale per maglieria e guanti, vano centrale con apertura maggiorata per tute e altro abbigliamento, pratico vano sottoborsa per le scarpe. Munito di ruote e maniglia estendibile a doppio scatto. Tasche esterne (due) e tracolla.

The bag for everything. Different spaces for helmets (with 10 mm foam protection), suits, gloves and shoes plus the big compartment at the bottom for any things.

RFBS0029_A



BS-300

500 x 360 x 150

Moderno zaino multi tasca, multiuso, con scomparto interno porta computer. Supporto posteriore in materiale traspirante (per limitare il sudore sulla schiena), reti portaoggetti ai lati. Molto leggero e pratico.

Rucksack with internal lap-top protected space, many pockets, soft protection for the back made of breathable net.

RFBS0025



BS-150

270 x 360 x 70

Borsa porta blocco delle note, molto sottile (per stare anche fra il sedile e la barra porta del roll cage), doppio scomparto porta telefono, portapenne esterno in testa per migliore salvaguardia degli spazi. Pannello di fissaggio posteriore, velcro e universale, adatto al fissaggio sulla barra porta.

Co-Driver bag, very thin. Velcro back panel for door bars universal fixation, twin compartment and mobile phone pocket.

RFBS0022



BS-110

440 x 330 x 100

Nuova borsa portatuta realizzata in tessuto nylon opaco e resistente. Pratica tasca anteriore e finestrella anteriore porta badge. *New driver suit's bag in matt and resistant nylon fabric. Practical front pocket and pass transparent pocket on the side.*

RFBS0006A



NEW SABELT SPORTSWEAR

